

# Instruction Manual

## Airbrush Diaphragm Compressor ASo6

34200



Illustration similar, may vary depending on model

Please read and follow the operating instructions and safety information prior to initial operation.

Technical changes reserved!

Illustrations, functional steps, and technical data may deviate insignificantly due to continuous further developments.



The information contained in this document may alter at any time without prior notice. No part of this document may be copied or otherwise duplicated without prior written consent. All rights reserved. WilTec Wildanger Technik GmbH cannot be held liable for any possible mistakes in this operating manual, nor in the diagrams and illustrations shown.

Although WilTec Wildanger Technik GmbH has made every possible effort to ensure that this operating manual is complete, accurate, and up-to-date, errors cannot be ruled out entirely.

If you have found an error or wish to suggest an improvement, we look forward to hearing from you.

Send us an e-mail to:

[service@wiltec.info](mailto:service@wiltec.info)

or use our contact form:

<https://www.wiltec.de/contacts/>

The most recent version of this manual in several languages can be found in our online shop:

<https://www.wiltec.de/docsearch>

Our postal address is:

WilTec Wildanger Technik GmbH  
Königsbenden 12  
52249 Eschweiler Germany

To return your goods for exchange, repair, or other purposes, please use the following address. Attention! To allow for a trouble-free complaint or return, it is important to contact our customer Serviceteam before returning your goods.

Retourenabteilung  
WilTec Wildanger Technik GmbH  
Königsbenden 28  
52249 Eschweiler Germany

E-Mail: **service@wiltec.info**

Phone: +49 2403 55592-0

Fax: +49 2403 55592-15



## Introduction

Thank you for choosing to purchase this quality product. To minimise the risk of injury, we ask you to always take some basic safety precautions when using this product. Please read this operating manual carefully and make sure that you understand it.

Keep these operation instructions in a safe place.

## Safety instructions

### **Caution!**

- The use of this device is only allowed with a fault current protection switch with a triggering nominal current up to 30 mA (according to VDE 0100 Article 702 and 738).
- The device is not intended for use by persons (including children) with impaired or limited physical, sensory, and mental abilities, or lack of experience and/or real knowledge, unless they are supervised by a person responsible for their safety or follow the instructions made by this person on how to correctly use the device.
- Children should be supervised to ensure that they do not play with the device.

### **Attention!**

- The compressor head can become very hot. **Burning hazard!**
- Perform a visual inspection of the device before every use. Do not use the device if the safety appliances are damaged or worn out. Never override safety regulations.
- Only use the device accordingly to the intended purpose stated in this manual.
- You are responsible for the safety of the working zone.
- If the cable or the plug is damaged due to external influences, the cable must not be repaired, but must be replaced with a new one. This work can only be carried out by an electrician.
- The voltage of 230 V AC indicated on the nameplate of the device must match the existent mains voltage.
- Never lift, transport, or suspend the device by its power cord.
- Make sure that the electrical plug connection is protected from flood and moisture.
- Before any maintenance work or adjustment, pull out the plug.
- The user is responsible for complying with local safety and mounting regulations. Ask an electrician if you have questions.
- In case of device failure, repairs can only be carried out by an electrician.

### **Notes!**

- Choose the right compressor with the appropriate air volume and air pressure to match the actual work requirements.
- Never expose the device to dust, acid, steam, explosive or flammable gases, or weather influences (rain, sun, fog, snow).
- The vacuum pump can only be operated in an appropriate environment (good ventilation, ambient temperature +5 °C–+40 °C).
- Never use the compressor barefoot or with wet hands or feet.
- Never allow children to touch the switched-on compressor or to insert the plug. It may cause burns or electric shocks.
- Do not open or damage any part of the compressor. If necessary, contact a qualified person.
- By opening the drain valve, the water can be evacuated. Always release the water before not using the compressor for a long time. Store the compressor in a well-ventilated place.
- Always wear protective goggles. Under no circumstances should you direct the airflow towards your body or other persons' bodies or animals.
- Never use the compressor in areas with vapours or humidity or near bodies of water.
- Switch off the compressor if you do not use it. Disconnect from mains before you repair, recondition, maintain, clean, or replace parts. Never use the power cable as handle. Keep the cable



away from heat, oil, or sharp edges. Protect it from breaking. Do not pull out the plug by pulling the power cable.

- If the compressor is used outdoors, only approved extensions may be used. Every wire of the extension cable must have at least a 1,5 mm<sup>2</sup> cross-section.
- Store the compressor in a well-ventilated place. Do not allow children or any other people not able to handle this device to play or work with it.
- Be very careful when working with the compressor. Do not perform work with this product when being unalert or influenced by alcohol, drugs, or medicine.
- When beginning work, make sure that all screws are tightened.
- Do not use the compressor if it is damaged. If the compressor makes unusual noises and strong vibrations or if other unusual signs occur that indicate some damage, immediately turn off the compressor. Do not modify the compressor in any way. Only have repairs made by qualified persons and using original spare parts.

### Properties

- Oil-free diaphragm compressor, no polluted air
- Overheating protection
- Very low noise level



### Use

The AS06 airbrush compressor is for example suitable for operating in the following areas: arts and crafts, hobbies, modelling, tattoos and body art, make-up, and nail design, as a source of air in the field of medicine, in food industry, chemical industry, laboratories, etc.

### Technical specifications

<b>Type</b>	Diaphragm compressor
<b>Power (W)</b>	250 (1/4 hp)
<b>Rotation speed (1/min)</b>	1450–1700
<b>Flow rate (1/min)</b>	65–68
<b>Pressure range (bar)</b>	0–3.5
<b>Weight (kg)</b>	4.5
<b>Size (mm)</b>	255×125×170
<b>Suitable nozzles (mm)</b>	0.2–1.0
<b>Sound level (dB (A))</b>	approx. 40
<b>Length of cable (m)</b>	1.9
<b>Hose connection (mm)</b>	13 (1/4")

### User notes

- The compressor has a 13 mm (1/4") outlet, which can be effortlessly changed to 1/8". The matching adapter is not included in the delivery.
- When the compressor is connected by the hose to the airbrush gun, it can be connected to the mains and switched on.
- The maximum pressure is displayed the pressure gauge, the operating pressure can be adjusted by the pressure regulator.



## Leakage check

- Switch on the compressor and wait until the maximum pressure has built up and the auto-stop function has been activated.
- If there is no leakage, the pressure gauge should display nearly constantly the same range of pressure.
- A quick decrease of the range of pressure suggests that there is in fact a leakage.
- It is of great importance to seal any leak as soon as possible to avoid any impact on the capacity and efficiency of the compressor.
- A leakage leads to the auto-stop and auto-start constantly being switched on and off.

## Difference between maximum pressure and operating pressure

- The maximum pressure is the highest possible pressure that a compressor can generate.
- The maximum pressure is the pressure measured only inside the compressor itself.
- Once the maximum pressure has been reached, the compressor switches off (auto-stop), and as soon as the pressure starts to decrease, it switches on again (auto-start).
- On the outlet of the compressor, there is a lower pressure. What remains is the pressure that you work with. The operating pressure may vary according to the connected airbrush gun.

## Troubleshooting

Problem	Cause	Solution
The engine does not run.	Damaged electric cables	Check electrical cable, replace it if necessary.
	Interior cable connections damaged	Open rear cover, check interior cable connections, repair them.
	On/off switch does not function	Check on/off switch, replace it if necessary.
The engine makes noises, but does not run.	Outlet completely clogged or closed	Unblock or open outlet.
	Wrong direction of cylinder valve after first assembly/disassembly made by the user	Reinstall cylinder valve and place it in the right direction.
Engine runs, but makes noises.	Bearings are loose or damaged	Replace bearings.
	Screws in connecting rod loose	Tighten or replace screws.
Airbrush-gun does not function properly, insufficient blowing pressure.	Air connection not tight.	Seal air connection with insulating tape.
	Air hose torn off	Re-mount the air hose.
	Screws of cylinder cover loose.	Tighten screws.
Engine runs smoothly, but generates no air pressure or no sufficient airflow.	Valve screws and diaphragm screws loose or in wrong position.	Open front cover, tighten screws, and place the diaphragm screws in right position.
	Valve destroyed because of too long a work with too high a pressure.	Replace valves or cylinder cover.

**Exploded view and parts list**

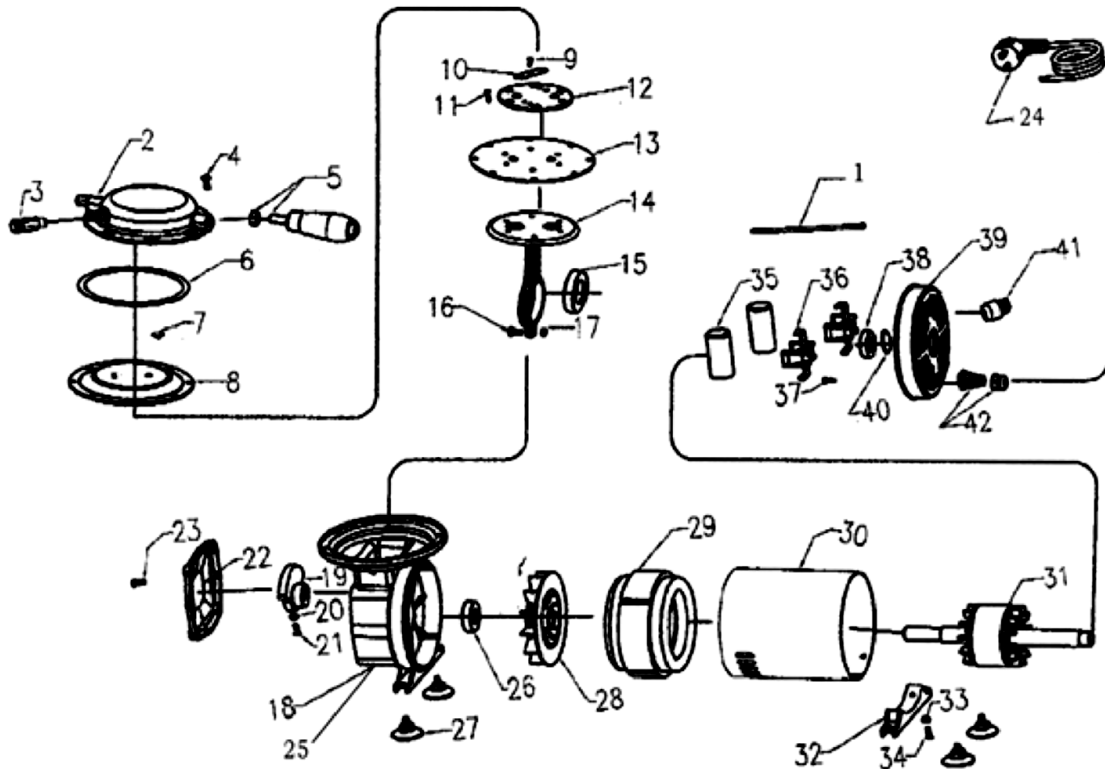

No	Name	No	Name	No	Name
1	Screw	15	Bearing	29	Shaft
2	Cylinder cover	16	Hexagon bolt	30	Main housing
3	Adjusting valve	17	Hexagon head nut	31	Rotor unit
4	Slotted screw (8×)	18	Cylinder head	32	Holder
5	Handle	19	Balance rod	33	Nut
6	Sealing ring	20	Hexagon head nut	34	Screw
7	Valve (3×)	21	Hexagon bolt	35	Capacitor (2×)
8	Separating plate	22	Front cover	36	Capacitor holder (2×)
9	Slotted screw	23	Slotted screw (4×)	37	Screw (2×)
10	Valve spring	24	Cable and plug	38	Bearing
11	Screw (6×)	25	Screw	39	Rear cover
12	Diaphragm fixing plate	26	Bearing	40	Cushion
13	Diaphragm	27	Rubber pad (4×)	41	Interrupter
14	Rod	28	Rotor	42	Pair of cable sleeves

## Regulations for waste disposal

The Waste Electrical and Electronic Equipment Directive (WEEE Directive, 2012/19/EU) of the EU was implemented in the German law related to electrical and electronic equipment and appliances.

All WilTec electric devices that fall under the WEEE directive are labelled with the symbol of a crossed-out wheeled rubbish bin. This symbol indicates that this electric device must not be disposed of with the domestic waste.

WilTec Technik GmbH is registered with the German registration authority EAR (Stiftung Elektro-Altgeräte Register) under the WEEE-registration number DE45283704.

Disposal of used electrical and electronic devices (intended for use in the countries of the European Union and other European countries with a separate waste collection system for these devices).

The symbol on the packaging or the product itself indicates that this product must not be treated as normal domestic waste but must be disposed of at a recycling collection station for electrical and electronic waste.

By disposing of this product correctly, you contribute to the protection of the environment and the health of your fellow people. Inappropriate disposal threatens the environment and health.



Material recycling helps to reduce the consumption of raw materials.

Additional information about the recycling of this product can be provided by your local commune, the municipal waste disposal facilities, or the store where you purchased the product.

Address:  
WilTec Wildanger Technik GmbH  
Königsbenden 12 / 28  
52249 Eschweiler Germany

Important Note:

Reproduction and any commercial use (of parts) of this operating manual, requires a written permission of WilTec Wildanger Technik GmbH.