

Operation Manual

Airbrush Compressor AS196AW

34246



Illustration similar, may vary depending on model

Read and follow the operating instructions and safety information before using for the first time.

Technical changes reserved!

Due to further developments, illustrations, functioning steps, and technical data can differ insignificantly.

Updating the documentation

If you have suggestions for improvement or have found any irregularities, please contact us.



The information contained in this document may alter at any time without previous notice. It is prohibited to copy or spread any parts of this document in any way without prior written allowance. All rights reserved.

The WilTec Wildanger Technik GmbH cannot be held accountable for any possible mistakes in this operating manual, nor in the diagrams and figures shown.

Even though, the WilTec Wildanger Technik GmbH has undergone biggest possible efforts to ensure that the operating manual is complete, faultless, and up to date, mistakes cannot be entirely avoided.

If you should find a mistake or wish to make a suggestion for improvement, we look forward to hearing from you.

Send an e-mail to:

service@wiltec.info

or use our contact form:

<https://www.wiltec.de/contacts/>

The most recent version of this manual in various languages can be found in our online shop via:

<https://www.wiltec.de/docsearch>

Our postal address is:

WilTec Wildanger Technik GmbH
Königsbenden 12
52249 Eschweiler
Germany

To return orders for exchange, repair, or other purposes, please use the following address. Attention! To allow for a smooth execution of your complaint or return, it is important to contact our customer service team before returning the goods.

Returns Department
WilTec Wildanger Technik GmbH
Königsbenden 28
52249 Eschweiler

E-mail: **service@wiltec.info**

Tel: +49 2403 55592-0

Fax: +49 2403 55592-15



Introduction

Thank you for purchasing this quality product. **To minimise the risk of injury we urge that our clients take some basic safety precautions when using this device. Please read the operation instructions carefully and make sure you have understood its content.**

Keep these operation instructions safe.

Safety precautions

BEWARE:

The use of this device is allowed only with fault current protection switch with a triggering nominal current up to 30 mA (according to VDE 0100 Article 702 and 738).

The device is not intended for use by persons (including children) with impaired or limited physical, sensory, and mental abilities, or lack of experience and/or real knowledge, unless they are supervised by a person responsible for their safety or the follow the instructions, made by this person on how to use the device correctly. Children should be supervised to make sure that they do not play with the device.

CAUTION:

- **The compressor head (with cooling fins) can get very hot.**
- Run a visual inspection of the device before every use. Do not use the device if the safety appliances are damaged or worn out. Never override safety regulations.
- Use the device exclusively according to the intended purpose stated in the manual.
- You are responsible for the safety of the working environment.
- If the cable or the plug is damaged due to external influences, the cable must not be repaired, but must be replaced with a new one. This work can only be carried out by an electrician.
- The 230 V alternating voltage indicated on the type plate of the device must correspond to the existent mains voltage.
- Never lift, carry, or fix the device by using the power cable.
- Make sure that the electrical plug connection is protected from flood and moisture.
- Disconnect the mains plug before starting the maintenance work at the compressor.
- The user is responsible for complying with the location specific safety and mounting regulations. Ask an electrician, if necessary.
- In case of device failure, the repairs can only be carried out by an electrician.

NOTES:

- The user should choose the right compressor with the appropriate air volume and air pressure to correspond to the actual work requirements.
- Never expose the device to dust, acid, steam, explosive or flammable gases, or atmospheric influences (rain, sun, fog, snow).
- The vacuum pump can be operated only in an appropriate environment (good ventilation, ambient temperature of +5–+40 °C).
- Never use the compressor barefoot or with wet hands or feet.
- Never allow children to touch the switched-on compressor or to insert the plug. It may cause burns or electric shocks.
- Do not open or damage any compressor part. If necessary, please contact your seller.
- Always release the water by opening the drain valve before not using the compressor for a long time. Store the compressor in a well-ventilated place.
- Always wear goggles. Under no circumstances direct the airflow towards your body or other persons' bodies or animals.
- Never use the device in areas with steam or moisture or close to water.
- Switch off the compressor if you do not use it. Disconnect it from mains before you repair, re-condition, maintain, clean, or replace parts. Never use the power cable as handle. Keep the

power cable away from hot objects, oil, and sharp edges. Protect it against breakage. Do not pull the power cable to unplug it from the power socket.

- If the compressor is used outdoors, only approved extensions may be used. Every wire of the extension cable must have at least 1,5 mm² cross-section.
- Do not store the compressor with the plug inserted into the socket. Do not allow children or any other people who are not able to handle this device to play or work with it.
- Be very careful when you are working with the compressor. Do not use it if you are tired. Persons under the influence of alcohol, drugs, or medicine are not allowed to use this device.
- When you start working make sure that all screws are tightened.
- Do not use the compressor if it is damaged. If the compressor generates unusual noises and strong vibrations or if other unusual signs occur that indicate some damage you should turn off the compressor immediately. For repairs, please use only original spare parts. Do not make any technical modifications to the compressor. In case you cannot eliminate the malfunction hand over the device to your seller.

Features

- Air tank supplies constant airflow without oscillatory airflows
- Without oil, piston compressor, no untidy air
- With water filter, pressure adjustment and manometer
- Double air pressure-switch:
 - 1st switch: Low-pressure auto-stop switch for airbrushing
 - 2nd switch: High-pressure switch without stop function, for other high pressure air tools
- Automatic start without counter pressure extends the stability of the engine.
- Protection against excessive temperature
- Safety device for the air tank.
- Very low noise level

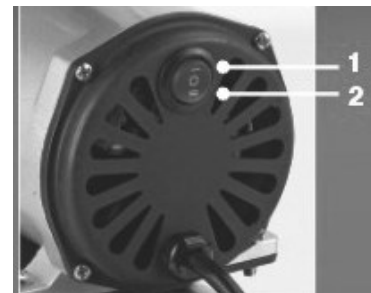

Fields of application

The AS196 AW Airbrush is among others suitable for the operation in the following areas:

- crafts,
- hobby,
- modelling,
- tattoos and body art,
- make-up and nail design,
- as a source of air in the medical field,
- in food and chemical industries,
- in laboratories etc.



Technical specifications

Type	Twin air compressor with tank and casing
Power (W)	190 (¼ PS)
Rotation speed (1/min)	1450–1700
Noise level (dB (A))	approx. 47
Stanrad volume (1/min)	35–40
Double switch	<u>1st switch</u> : auto-start at 2 bar, auto-stop at 4 bar <u>2nd switch</u> : max. pressure 6 bar, no auto-stop
Pressure adjustment range (bar)	0–4
Real continuous operation pressure (bar)	0.35–2.5
Air tank (ℓ)	3
Weight (kg)	10.9
Size (mm)	350×140×360
Cable length (m)	1.9

Notes:

- The compressor has a 9,51 mm outlet (⅜", male thread), which can be effortlessly changed to ¼". The matching adapter is not included in the supply.
- When the compressor is connected by the hose to the airbrush gun, the compressor can be connected to the mains and be switched on.
- The maximum pressure is displayed by the pressure gauge, the operating pressure can be adjusted by the pressure regulator.
- If the auto-stop mode is activated (repeatedly switch on/off) all screw fittings and connections should be sealed by a teflon tape.

Leakage control

- Switch on the compressor and wait until the maximum pressure has built up and the auto-stop function has been activated.
- If there is no leakage, the pressure gauge should display nearly constantly the same range of pressure.
- A quick decrease of the range of pressure suggests that there is in fact a leakage.
- It is of great importance to seal any leak as soon as possible to avoid any impact on the capacity and efficiency of the compressor.
- A leak causes the auto-stop and auto-start function to be carried out permanently.

Difference between maximum and operating pressure

- The maximum pressure is the highest possible pressure a compressor can generate.
- Once the maximum pressure has been reached, the compressor switches off (auto-stop). As soon as the pressure starts to decrease, it switches on again (auto-start).
- Maximum pressure is the pressure measured inside the compressor.
- There is a lower pressure on the outlet of the compressor. The pressure that you work with remains. The operating pressure may vary according to the connected airbrush gun.

Operation of the pressure relief station with filter



Letter	Name
a	Pressure regulator
b	Pressure gauge
c	Water drain plug

Product name: Pressure regulator with filter and pressure gauge

Type: AFR-2000

Features:

The AFR-2000 is an in-line low pressure regulator with 9 bar (100 psi) manometer and water drain plug. This regulator allows you to control the pressure and helps generating clean, dry, pressure-stable air. The regulator can be used only according to the operating instructions.

Operation:

- The pressure gauge reports the air tool working pressure.
- Pull up the adjusting knob; its being clockwise rotated increases the pressure, a counter-clockwise rotation reduces the pressure.
- Rotate the adjusting knob to achieve the right working pressure and lock it downwards by clicking it into place.
- Do not rotate the knob against high resistance. If necessary, the height and the position of the of the knob can vary slightly.
- For emptying the condensed water collector use the water drain plug.

Main components

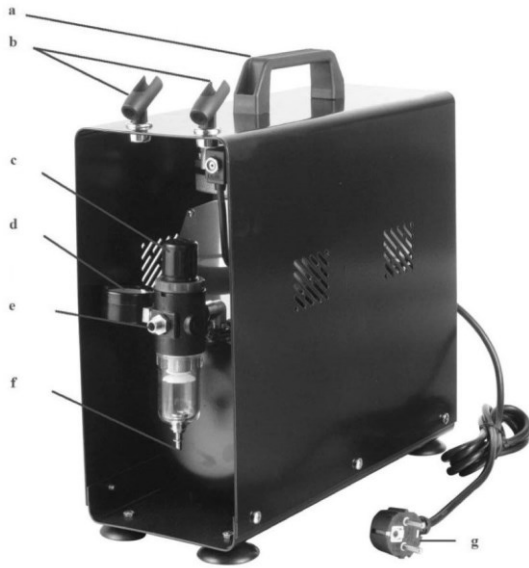

Letter	Name
a	Handle
b	Airbrush gun holder
c	Pressure regulator
d	Pressure gauge
e	Air outlet
f	Water drain plug
g	Mains plug

Exploded view and parts list

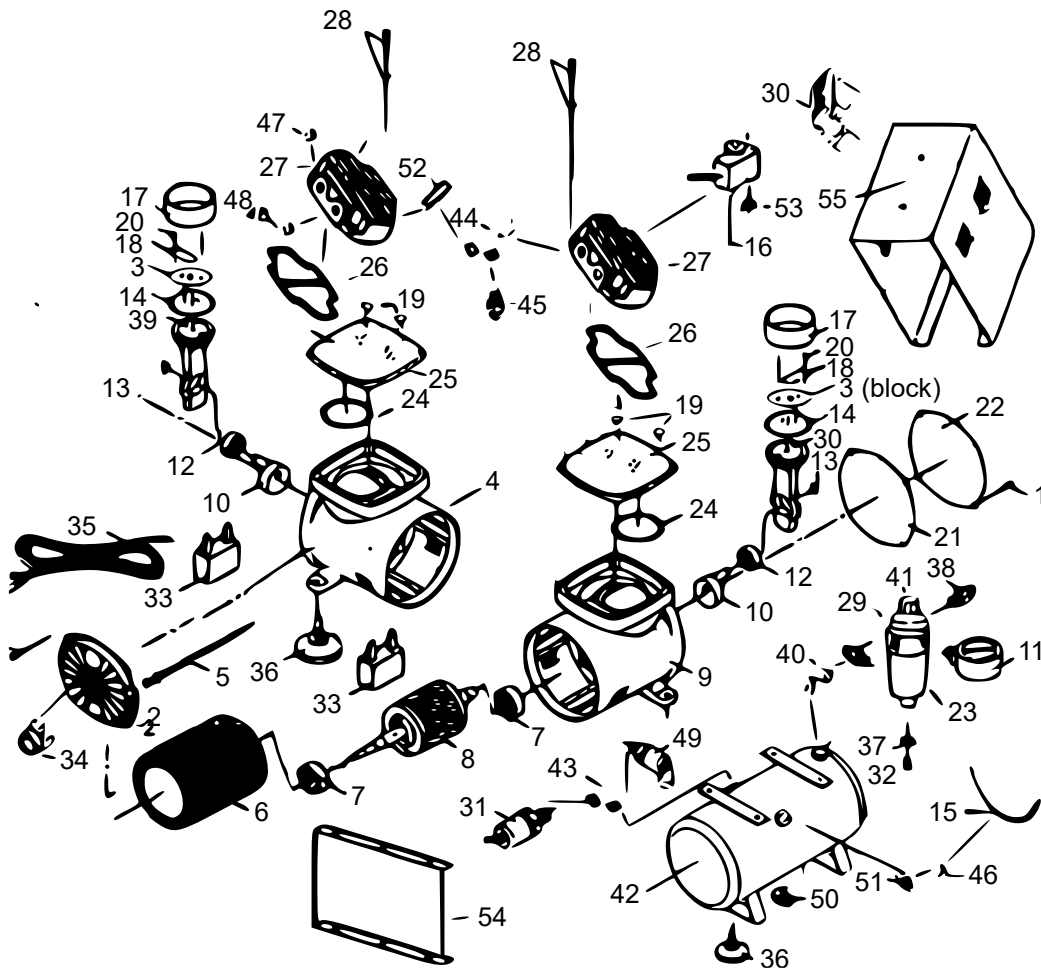



№	Name	Qty.	№	Name	Qty.
1	Screw	8	29	Filter valve	1
2	Rear cover	1	30	Handle	1
3	Block	2	31	Pressure switch	1
4	Rear body	1	32	Water drain valve	1
5	Screw	4	33	Condenser	2
6	Stationary motor	1	34	Power switch	1
7	Bearing	2	35	Wire	1
8	Rotary motor	1	36	Rubber pad	4
9	Front body	1	37	Hexagon nut	1
10	Counterweight	2	38	Connector	2
11	Pressure gauge	1	39	Link	2
12	Bearing	2	40	Adaptor	1
13	Retainer ring	2	41	Pressure regulator	1
14	Compression ring	2	42	Tank	1
15	Pipe	1	43	Three-way manifold	1
16	Solenoid valve	1	44	Three-way manifold	1
17	Cylinder	2	45	Non-return valve	1
18	Valve plate	2	46	Pipe nut	1
19	O-ring	4	47	Plug	1
20	Screw	2	48	Muffle	1
21	Front gasket	1	49	Security valve	1
22	Front cover	1	50	Drain valve	1
23	Filter	1	51	Adaptor	1
24	O-ring	1	52	Pipe	1
25	Cylinder block	2	53	Screw nut	1
26	O-ring	2	54	Base	1
27	Cylinder head	2	55	Cover	1

Disposal regulations

EU guidelines regarding the disposal of scrap electric appliances (WEEE, 2012/19/EU) were implemented in the law related to electrical and electronic equipment and appliances.

All WiTec electric devices that fall under the WEEE regulations are labelled with the crossed-out wheeled waste bin logo. This logo indicates that this electric equipment must not be disposed with the domestic waste.

The company WiTec Technik GmbH has been registered in the German registry EAR under the WEEE-registration number DE45283704.

Disposal of used electrical and electronic appliances (intended for use in the countries of the European Union and other European countries with a separate collection system for these appliances).

The logo on the article or on its packaging points out that this article must not be treated as normal household waste but must be disposed to a recycling collection point for electronic and electrical waste equipment. By contributing to the correct disposal of this article you protect the environment and the health of your fellow men. Environment and health are threatened by inappropriate disposal.



Material recycling helps reduce the consumption of raw materials.

Additional information on recycling this article can be provided by your local community, municipal waste disposal facilities, or the store where you purchased the article.

Address:
WiTec Wildanger Technik GmbH
Königsbenden 12 / 28
D-52249 Eschweiler

Important notice:

The reprint or reproduction, even of excerpts, and any commercial use, even in part, of this instruction manual require the written permission of WiTec Wildanger Technik GmbH.