

Operation Manual

Tyre Wall Holder

51484



Illustration similar, may vary depending on model

Read and follow the operating instructions and safety information before using for the first time.

Technical changes reserved!

Due to further developments, illustrations, functioning steps, and technical data can differ insignificantly.

Updating the documentation

If you have suggestions for improvement or have found any irregularities, please contact us.



The information contained in this document may alter at any time without previous notice. It is prohibited to copy or spread any parts of this document in any way without prior written allowance. All rights reserved.

The WilTec Wildanger Technik GmbH cannot be held accountable for any possible mistakes in this operating manual, nor in the diagrams and figures shown.

Even though, the WilTec Wildanger Technik GmbH has undergone biggest possible efforts to ensure that the operating manual is complete, faultless, and up to date, mistakes cannot be entirely avoided.

If you should find a mistake or wish to make a suggestion for improvement, we look forward to hearing from you.

Send an e-mail to:

service@wiltec.info

or use our contact form:

<https://www.wiltec.de/contacts/>

The most recent version of this manual in various languages can be found in our online shop via:

<https://www.wiltec.de/docsearch>

Our postal address is:

WilTec Wildanger Technik GmbH
Königsbenden 12
52249 Eschweiler
Germany

To return orders for exchange, repair, or other purposes, please use the following address. Attention! To allow for a smooth execution of your complaint or return, it is important to contact our customer service team before returning the goods.

Returns Department
WilTec Wildanger Technik GmbH
Königsbenden 28
52249 Eschweiler

E-mail: **service@wiltec.info**

Tel: +49 2403 55592-0

Fax: +49 2403 55592-15

Introduction

Thank you for purchasing this quality product. **To minimise the risk of injury we urge that our clients take some basic safety precautions when using this device. Please read the operation instructions carefully and make sure you have understood its content.** Keep these operation instructions safe.

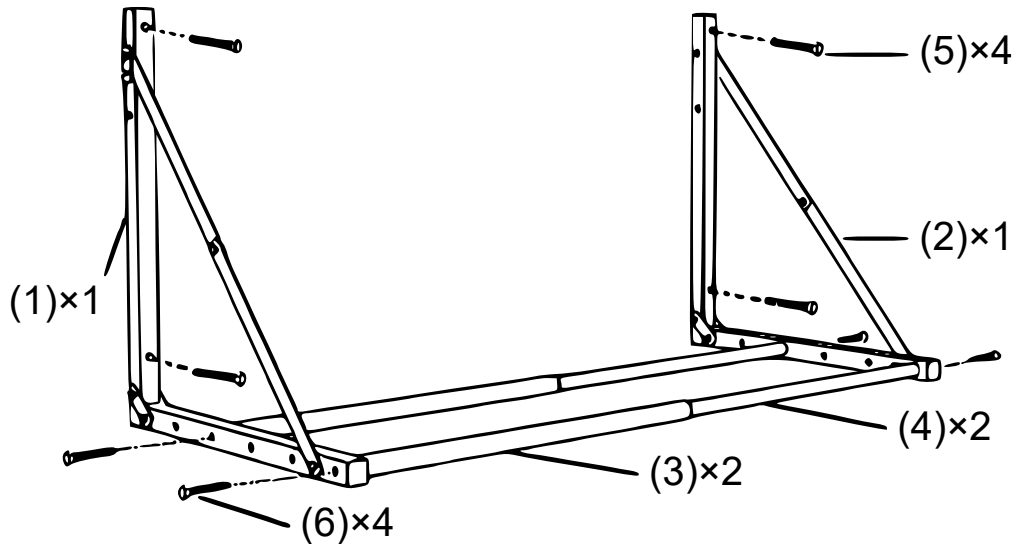

Technical data

Size (mm)	780–1370×730×705
Width of holder (cm)	81–122
Size of wheels (inch)	12–18
Max. number of wheels	4
Capacity (kg)	130

Assembly instructions

1. First install the two main parts of this folding tyre rack, as shown on the photos on the right. Connect the upright support and horizontal support on their end with two little brackets, using two sets of M10×50 bolt and nut. You will get an L frame. Join the connecting long thin brackets using an M20 bolt and nut; afterwards connect this part to the L frame, one end meeting the upright support and the other end meeting the horizontal support. Please remember to put a M8 nut as a spacer between the bracket and the horizontal support. Assembly the other main part, exactly like this first one.

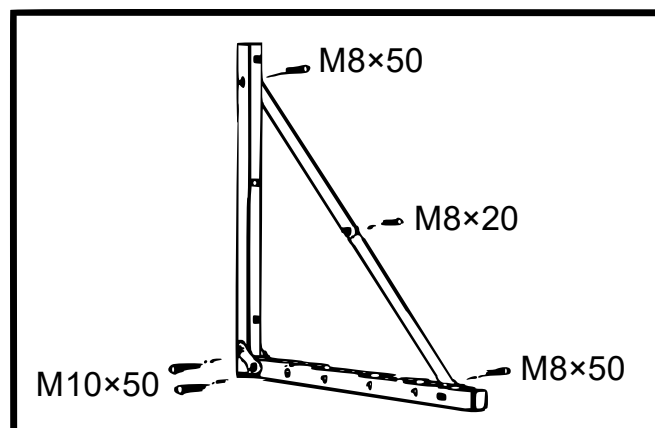

2. Mounting the upright supports to the wall studs: Install 2 wall studs that are 32" to 48" apart (measured from their centre). Make sure the holes are on the same level of height. Pre-drill the 2 marked holes using a 3/16" drill bit (M: 32" to 48" centres).

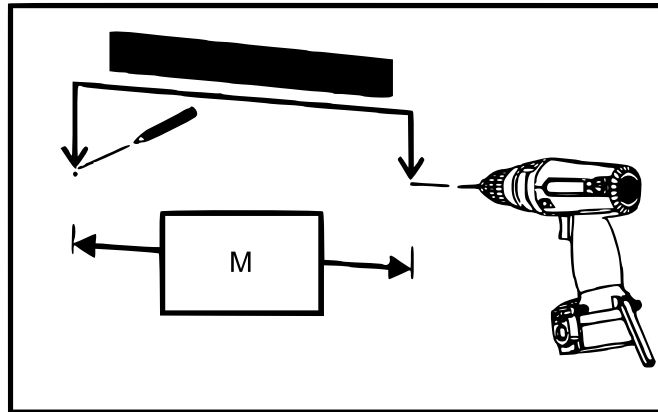

IMPORTANT NOTES:

- a) The unit **MUST** be installed on wall studs. Do not use wall anchors for mounting directly to sheet rock.
- b) Do not overtighten the lag screws (max. 13,6 Nm/10 ft.lbs.). They only need to be fully seated.

3. Mount parts (1) and (2) with expansion screws (5) (not supplied due to different standard). Do not fully tighten the top screws now. The brackets must be at the same level. Make the remaining two holes and fasten them with screws (5). Fully tighten all screws.

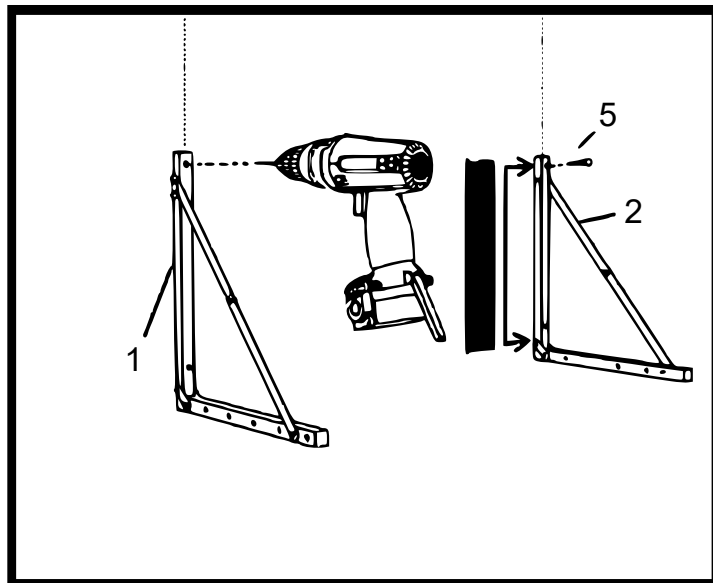

4. Attach the round tubes: Insert tubes (4) into tubes (3), fasten them to the brackets (1, 2) with bolts (6), in the position that best supports your tyres.

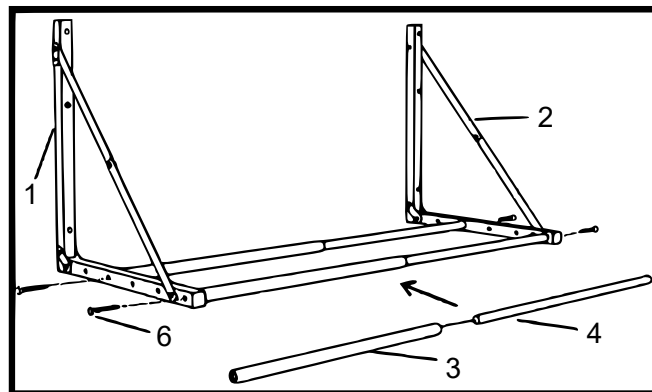

5. Tighten, adjust, and fold: All fasteners must be fully tightened. Store the unit in a folded position as shown.

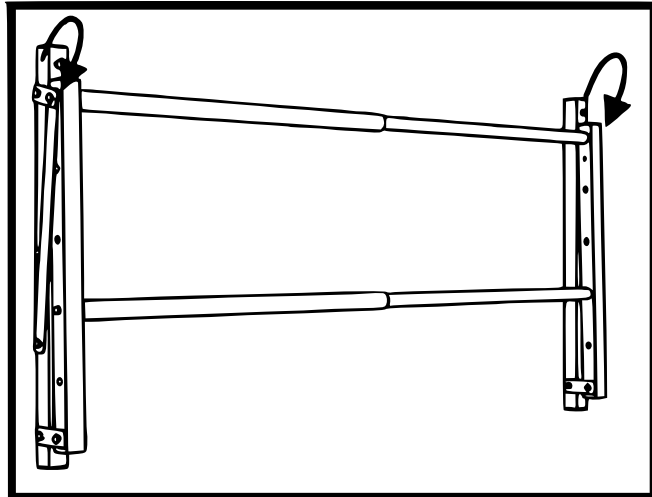

Important notice:

The reprint or reproduction, even of excerpts, and any commercial use, even in part, of this instruction manual require the written permission of WilTec Wildanger Technik GmbH.