

# Operation Manual

## Engine Mounting Support

51745



Illustration similar, may vary depending on model

Read and follow the operating instructions and safety information before using for the first time.

Technical changes reserved!

Due to further developments, illustrations, functioning steps, and technical data can differ insignificantly.

Updating the documentation

If you have suggestions for improvement or have found any irregularities, please contact us.



The information contained in this document may alter at any time without previous notice. It is prohibited to copy or spread any parts of this document in any way without prior written allowance. All rights reserved.

The WilTec Wildanger Technik GmbH cannot be held accountable for any possible mistakes in this operating manual, nor in the diagrams and figures shown.

Even though, the WilTec Wildanger Technik GmbH has undergone biggest possible efforts to ensure that the operating manual is complete, faultless, and up to date, mistakes cannot be entirely avoided.

If you should find a mistake or wish to make a suggestion for improvement, we look forward to hearing from you.

Send an e-mail to:

[service@wiltec.info](mailto:service@wiltec.info)

or use our contact form:

<https://www.wiltec.de/contacts/>

The most recent version of this manual in various languages can be found in our online shop via:

<https://www.wiltec.de/docsearch>

Our postal address is:

WilTec Wildanger Technik GmbH  
Königsbenden 12  
52249 Eschweiler  
Germany

To return orders for exchange, repair, or other purposes, please use the following address. Attention! To allow for a smooth execution of your complaint or return, it is important to contact our customer service team before returning the goods.

Returns Department  
WilTec Wildanger Technik GmbH  
Königsbenden 28  
52249 Eschweiler

E-mail: **service@wiltec.info**

Tel: +49 2403 55592-0

Fax: +49 2403 55592-15

## Introduction

Thank you for purchasing this quality product. **To minimise the risk of injury we urge that our clients take some basic safety precautions when using this device. Please read the operation instructions carefully and make sure you have understood its content.**

Keep these operation instructions safe.

## Description

The motor carrier, loadable up to a weight of 900 kg, provides an ideal help for working on engines or transmissions. A large variety of adjustments and adaption possibilities guarantee a high degree of flexibility and security. While working turn the engine about 360° to get access even to those areas that are difficult to reach. The four installation points can be easily adjusted regarding angle and distance and thus allow a universal adjustment for any engine. There are four steel rollers that ensure a safe position and make for an easy drivability of the entire construction.

## Safety instructions/warnings



The owner and/or user must have read and understood the operating instructions of the device before using it. Installed personnel should be cautious, competent, trained and qualified in the safe handling of the working equipment used when working on engines and their components. Warnings should be read and understood.

- Be familiar with the application control, the application process and the warnings.
- The engine stand may only be used for the removal and installation of engines (gears, differential gears, etc.).
- Ensure that all connectors are secure.
- Make sure you know the contents of the instructions for use.
- This device is not intended to be used by persons (including children) with reduced physical, sensory, or mental abilities or persons who do not have the appropriate experience or knowledge, unless they are supervised by a person responsible for their safety or have previously been instructed on how to use the device.
- Children must be supervised to ensure that they do not play with the appliance.
- Ensure that the load is free and no obstacles prevent the lifting.
- The engine stand may only be pushed slowly over level ground with load when fully lowered.
- Ensure that the load cannot slip.
- Check the loading balance after a few centimetres before proceeding.
- The charge may not swing.
- Ensure that no one is near the load.
- Warn the present persons before lifting the charge.
- Immediately report to your supervisor or workshop as soon as something unforeseen happens.
- Never lift more than maximum allowed.
- Never use damaged non-functioning engine stand.
- Never use bent, damaged or worn load-bearing devices.
- Never lift the load if an obstacle could interfere with the lift.
- Stay concentrated and do not allow any distraction during the process.
- Never use the load receptacle to lift, help or transport people.
- **NEVER LIFT LOADS OVER PERSONS' HEADS!**
- Unsecured loads can result in injuries to limbs or bones, including fatal injuries.
- Avoid contact between the engine stand and other objects.

- Never attempt to extend or repair the load receptacle.
- Do not use welding equipment near the support.
- Always pay attention to the optimal lighting of the workplace.
- Be sure to wear solid footwear.
- Use a hairnet for long hair.
- Wear tight clothing.
- Take off jewellery (rings, earrings, watches, etc.).
- Be careful not to wear loose straps or belts.
- Only use the engine stand if you feel physically capable of doing so.
- Long working in a standing position can lead to dizziness. Make regular breaks and drink enough.
- Only use the engine stand on straight and solid ground that can carry the specified loads.
- Before beginning to work on/under a vehicle, ensure that the vehicle is properly raised and secured.
- Never open the screw connections under pressure/load.

### Parts list and exploded view

No	Name	Qty.
1	M8 nut	16
4	M8×20 bolt	16
5	M14 nut	9
6	M14 lock washer	9
7	M14 washer	9
8	M14×100 bolt	5
9	Large castor	4
10	M8×100 bolt	8
11	Pin 16×110	4
12	M14×60 bolt	4
13	Locking pin	1
14	Small castor	2
15	R Clip	4

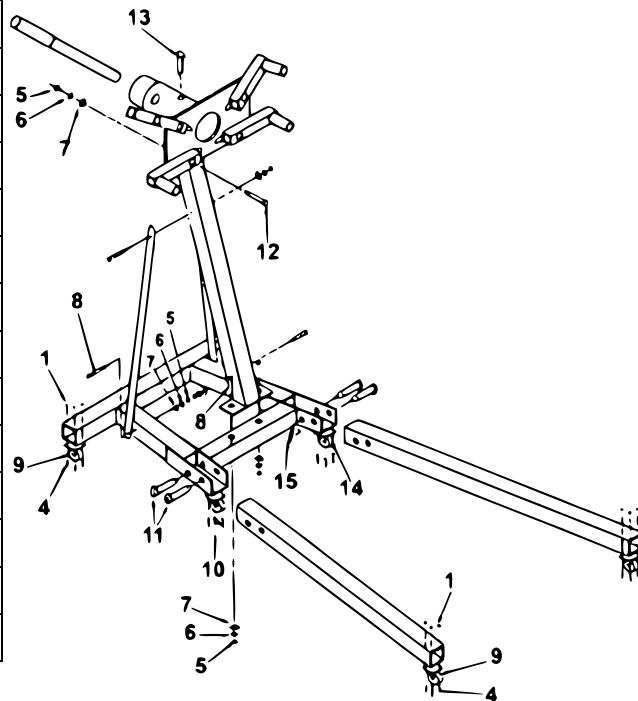

### Technical data

<b>Max. capacity (kg)</b>	900
<b>Width (mm)</b>	820
<b>Length (mm)</b>	1105
<b>Height (mm)</b>	910





## Assembly

1. Bolt the large castor wheels **(9)** to the rear-most mountings on the main frame and to the legs using M8×20 bolts **(4)**, M8 washers **(3)**, M8 lock washers **(2)**, and M8 nuts **(1)**. Bolt the small castor wheels **(14)** to the forward mountings on the main frame using M8×14 bolts **(10)**, M8 washers **(3)**, M8 lock washers **(2)**, and M8 nuts **(1)**.
2. Assemble the legs to the frame using the 16×110 pins **(11)**. Lay each leg into the open channel and insert the first pin into the hole nearest the rear of the frame. This will be the folding leg pivot. Retain the pin with a R clip **(15)**. Lock the leg in the down position by inserting a second 16×110 pin **(11)** into the hole nearest the open end of the channel and retain with a R clip **(15)**.
3. Bolt the main upright to the cross member between the open channel using two M14×100 mm bolts **(8)**, M14 washers **(7)**, M14 lock washers **(6)**, and M14 nuts **(5)**. Do not fully tighten the nuts at this stage.
4. Take the two support struts and loosely bolt them to the top of the main upright using a M14×100 bolt **(8)**. Insert two M14 bolts **(8)** through the angled parts of the main base in the holes adjacent to the rear square section ensuring that the bolt heads are on the outside of the frame. Slide the bottom of each support strut over the end of each bolt in turn and secure with the nuts and washers provided. Fully tighten all the nuts and bolts holding the main upright and struts.
5. Take the engine mounting plate and insert it through the tube at the top of the main upright. Rotate the plate until one of the holes in the inner tube is aligned with a hole in the outer tube and insert the locking pin **(13)**.
6. Take the handle and insert it into the hole in the part of turning plate tube protruding through the top of the main upright.
7. Attach the adjustable mountings to the turning plate using M14×60 bolts **(12)**, M14 washers **(7)**, M14 lock washers **(6)**, and M14 nuts **(5)**.
8. To fold up the legs remove the R clips **(15)** from the 16×110 pins **(11)** furthest from the rear of the frame and pull out the pins. Fold the legs up. Always retain the legs in the upright position by re-inserting the pins **(11)** through the holes in the frame directly in front of the folded legs. Retain the pins **(11)** with the R clips **(15)**.

### Important notice:

The reprint or reproduction, even of excerpts, and any commercial use, even in part, of this instruction manual require the written permission of WiITec Wildanger Technik GmbH.