

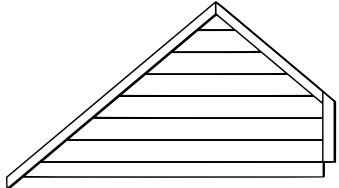

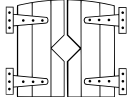



N°	Figure	Qté	N°	Figure	Qté
1		1	10		2
2		1	11		1
			12		1
3		1	13		1
4		1	14		1
			15		1
5		1	16		1
			17		1
6		1	18		1

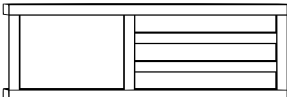

7		1						
8		1				1		
						1		
						2		
						2		
						2		
				 13-mm-Abstandhalter (Espaceur de 13 mm)		2		
9		1						

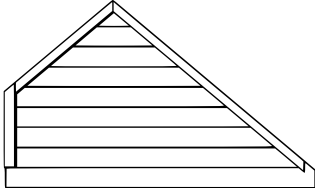
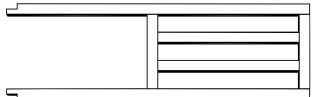
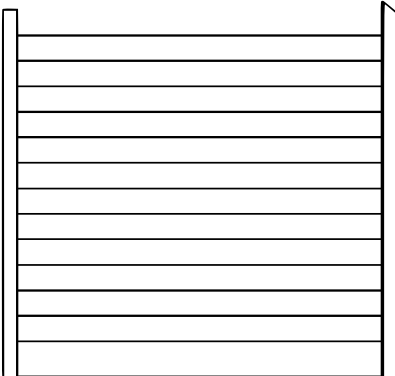
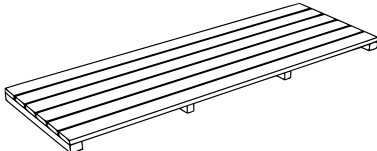
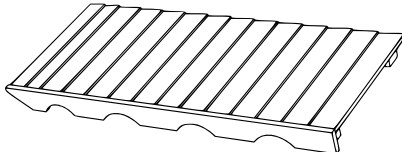
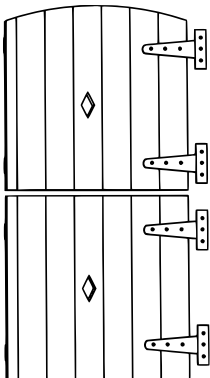
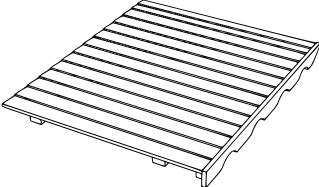
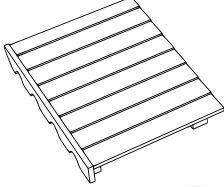
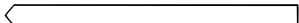
A	B	C	D	E	F	G	H	I
 3,5×60	 3,5×50	 3,0×30	 3,0×25	 3,0×20	 3,0×16	 3,5×24		
4	26	14	16	39	36	8	8	4

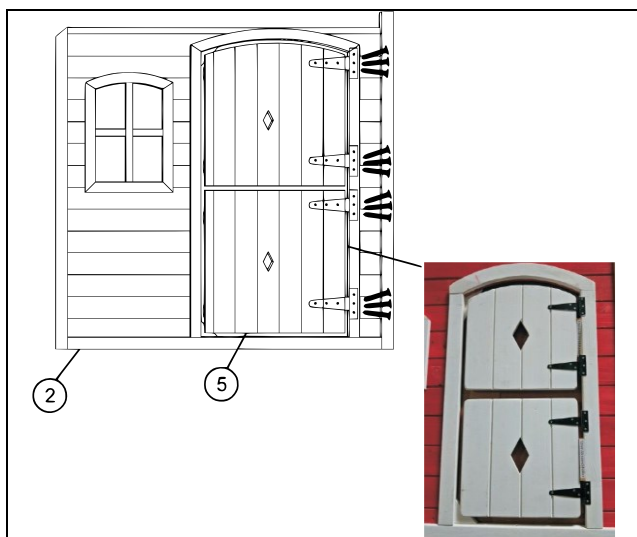

Étape 1 | F×12

Lors de l'assemblage de la porte et de la fenêtre, laissez un espace de 13 mm pour éviter un pincement ultérieur.

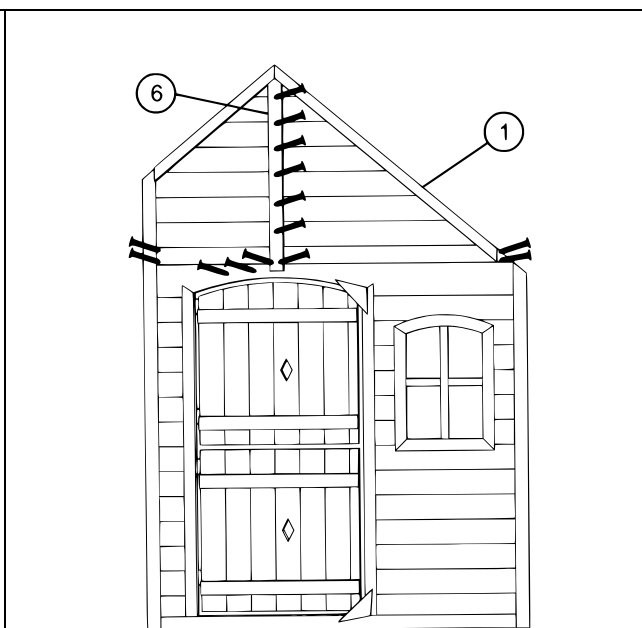

Étape 2 | E×14

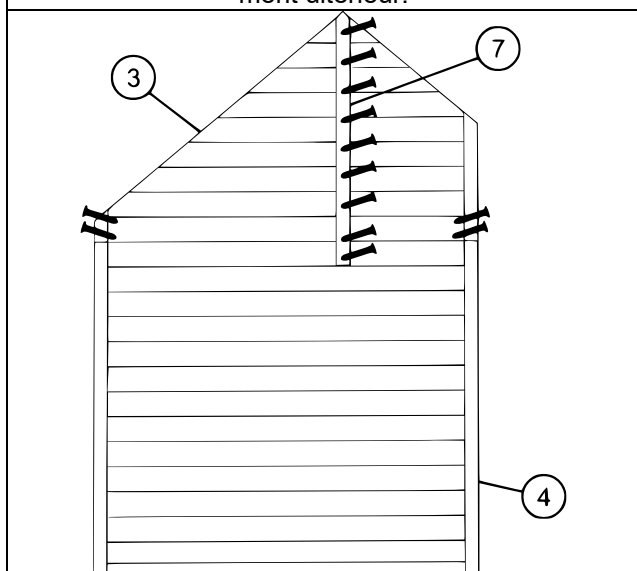

Étape 3 | E×13

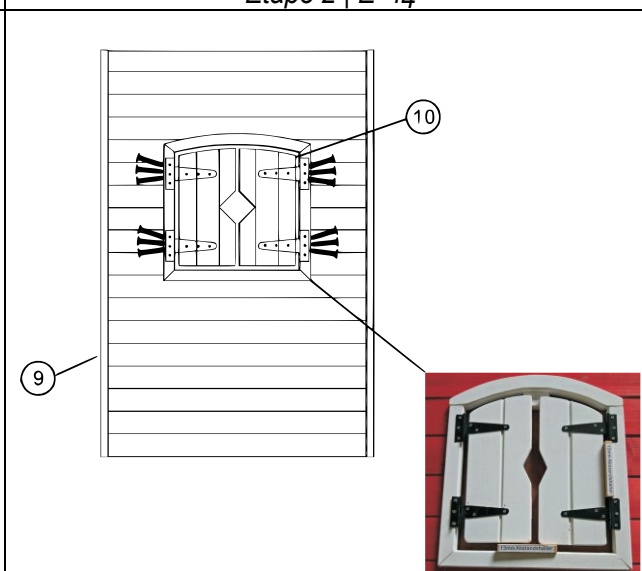

Étape 4 | F×12

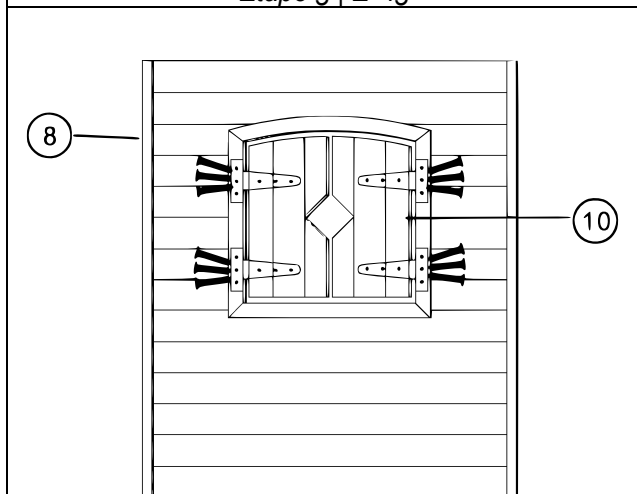

Étape 5 | F×12

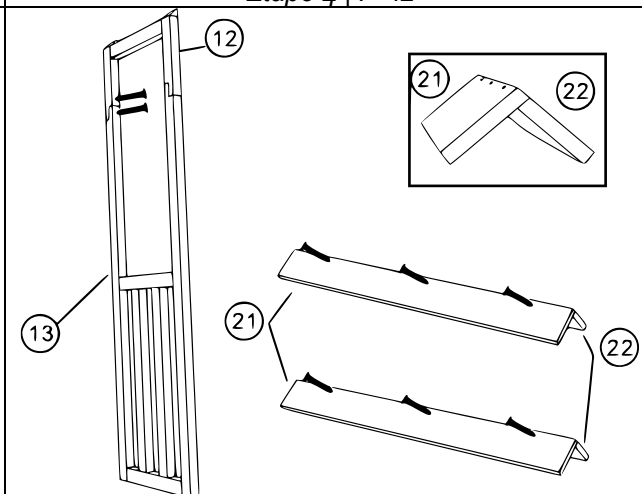

Étape 6 | C×8

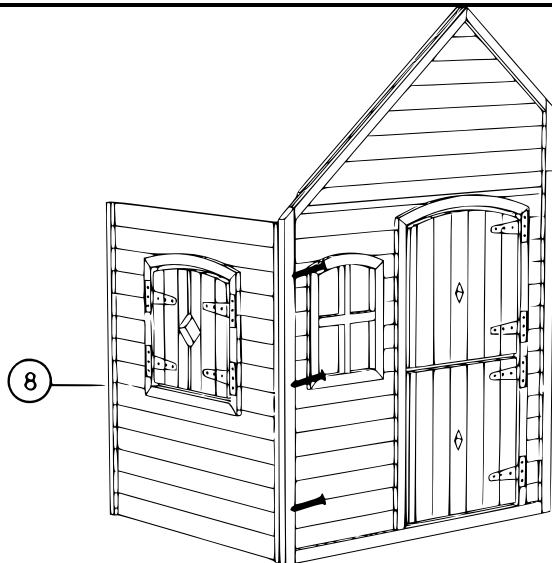

Étape 7 | B×3

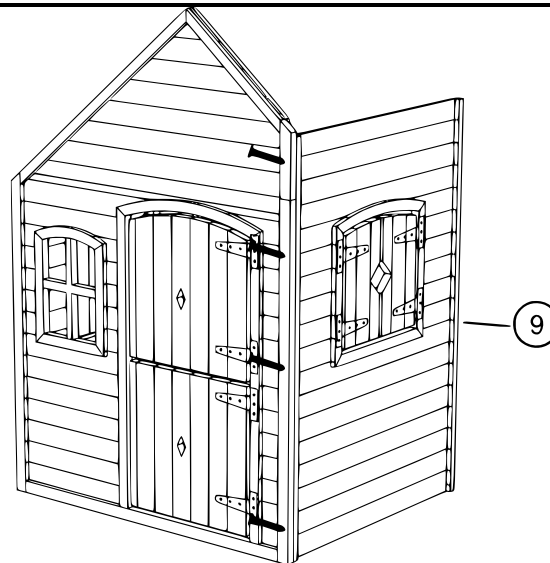

Étape 8 | B×4

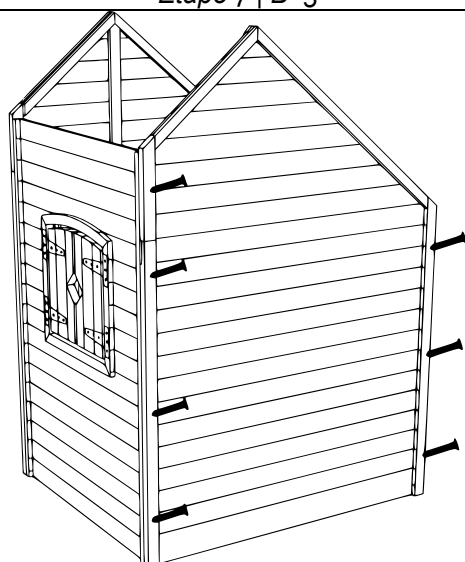

Étape 9 | B×7

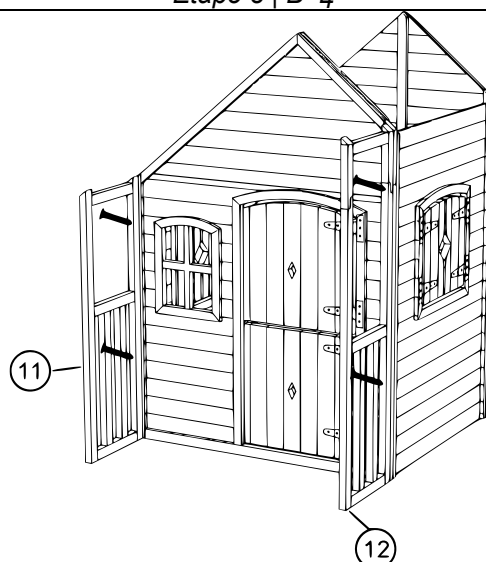

Étape 10 | A×4

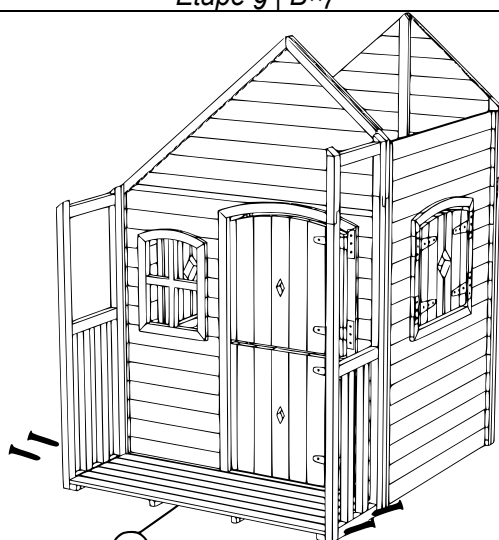

Étape 11 | B×4

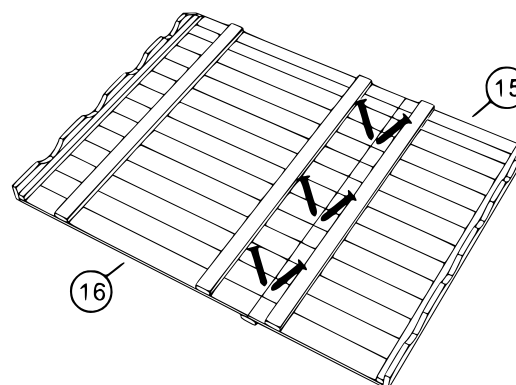

Étape 12 | E×6

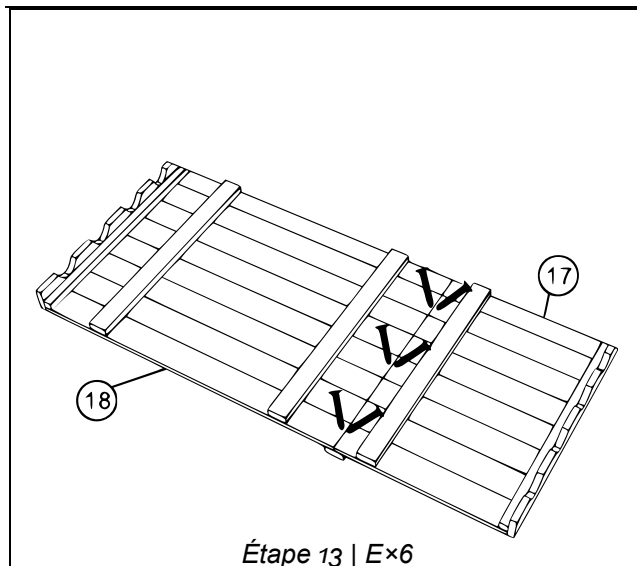

Étape 13 | E×6

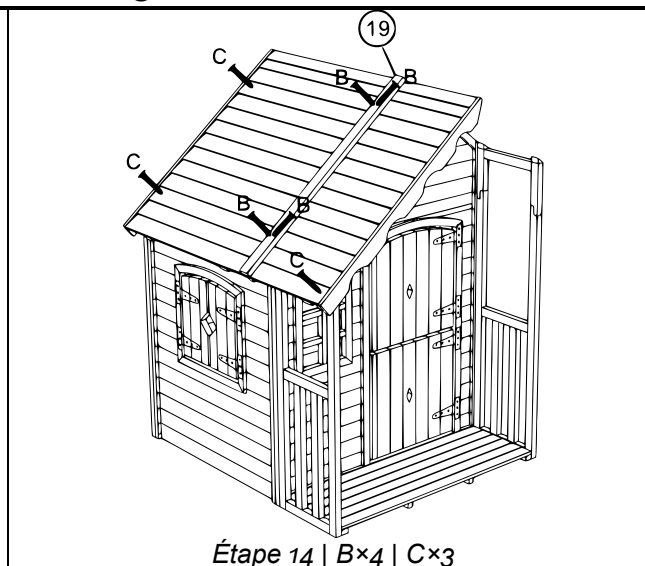

Étape 14 | B×4 | C×3

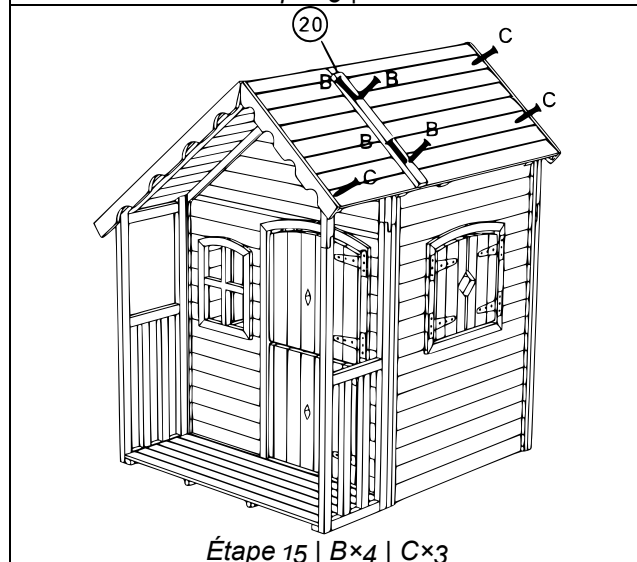

Étape 15 | B×4 | C×3

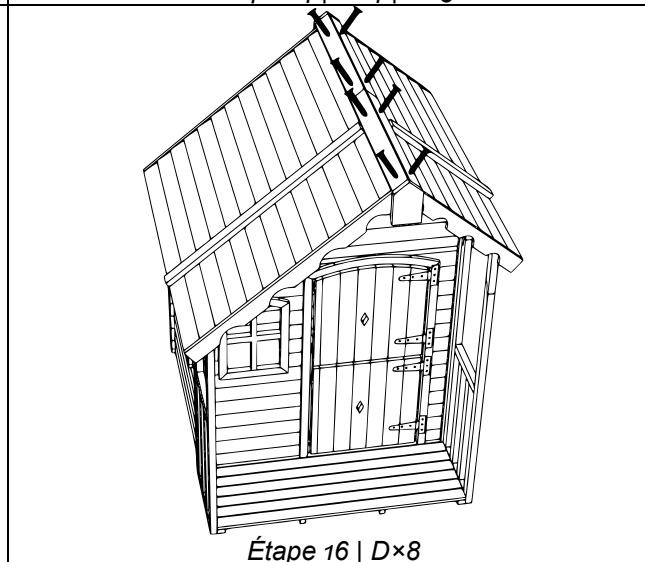

Étape 16 | D×8

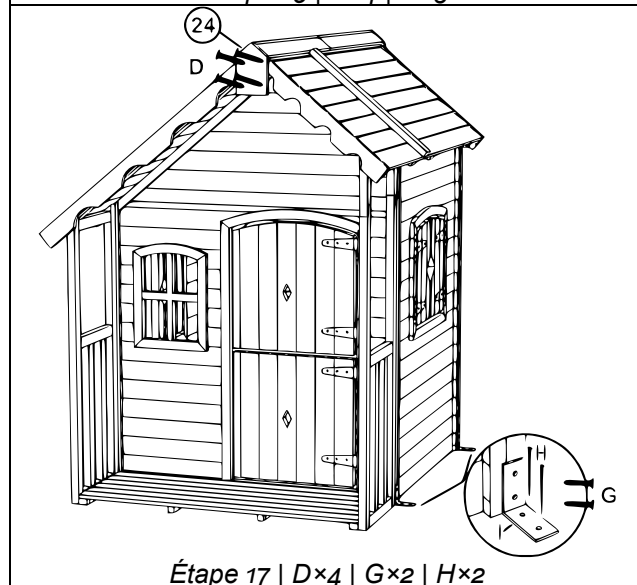

Étape 17 | D×4 | G×2 | H×2

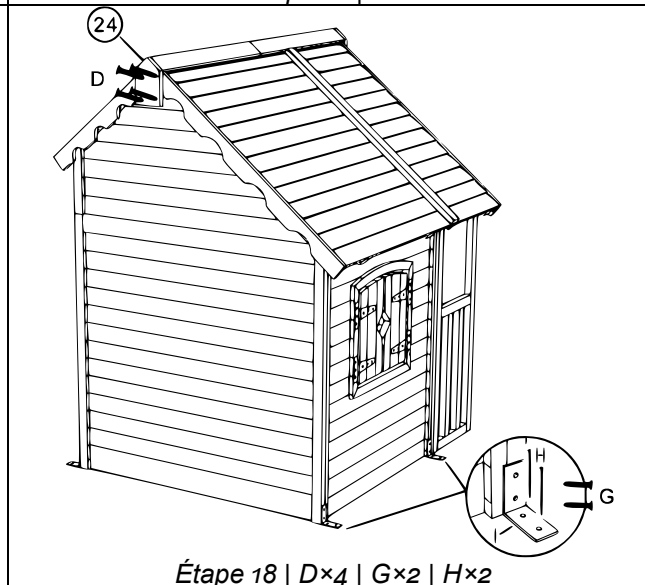

Étape 18 | D×4 | G×2 | H×2

Avis important :

Toute reproduction et toute utilisation à des fins commerciales, même partielle de ce mode d'emploi, ne sont autorisées qu'avec l'accord préalable de la société WilTec Wildanger Technik GmbH.