

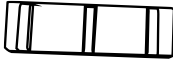













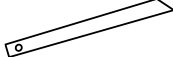

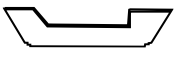
## 60192 – Cage pour rongeurs

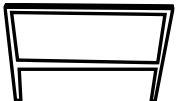
Lettre	Dénomination	Fig.	Qté	Lettre	Dénomination	Fig.	Qté
<b>A</b>	Panneau de pa-roi arrière		1	<b>M</b>	Bascule		2
<b>B</b>	Panneau latéral arrière		2	<b>N</b>	Pièce de base de bascule		2
<b>C</b>	Panneau latéral avant		2	<b>O</b>	Bol d'eau		1
<b>D</b>	Panneau de sol latéral		2	<b>P</b>	Barre de couvercle		1
<b>E</b>	Tablette inférieure		1	<b>Q</b>	Boucle de porte		1
<b>F</b>	Tablette supérieure		1	<b>A<sub>1</sub></b>	Vis (M4×25 mm)		34
<b>G</b>	Panneau de pa-roi frontale		1	<b>A<sub>2</sub></b>	Vis (M3×20 mm)		2
<b>H</b>	Panneau de pa-roi frontale		1	<b>A<sub>3</sub></b>	Vis (M3×10 mm)		36
<b>I</b>	Panneau de sol intermédiaire		1	<b>A<sub>4</sub></b>	Charnière		5
<b>J</b>	Couvercle		1	<b>A<sub>5</sub></b>	Axe en bois		1
<b>K</b>	Rampe		3	<b>A<sub>6</sub></b>	Pommeau		1
<b>L</b>	Pièce de ca-bane latérale		2				

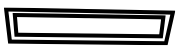
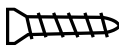

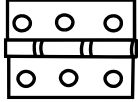
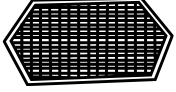
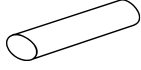
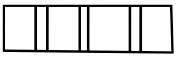
# ASSEMBLAGE

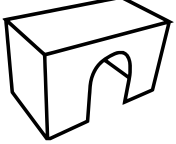
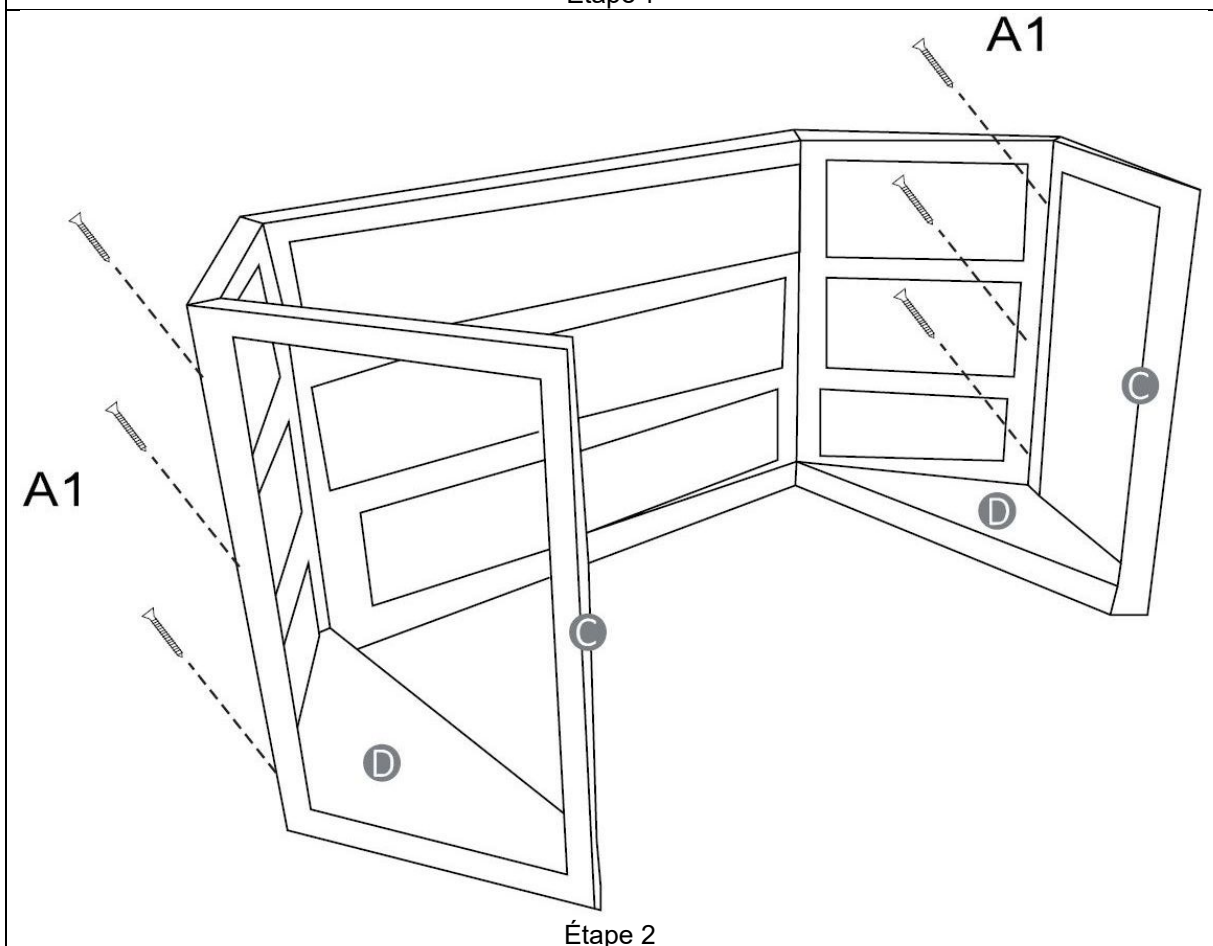
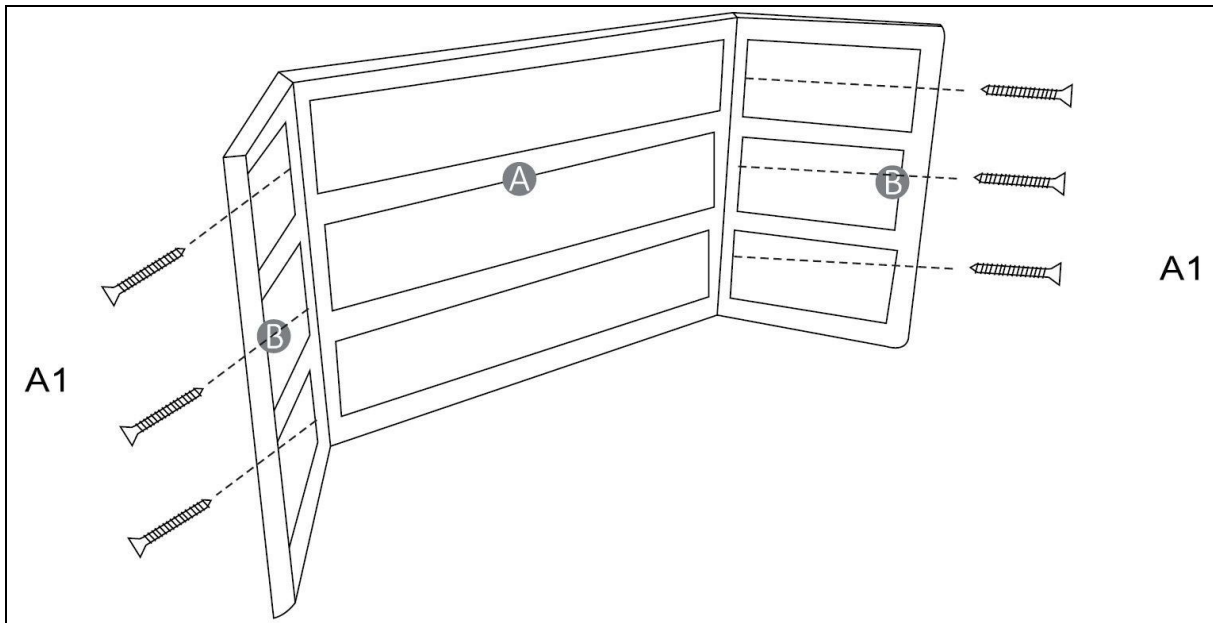
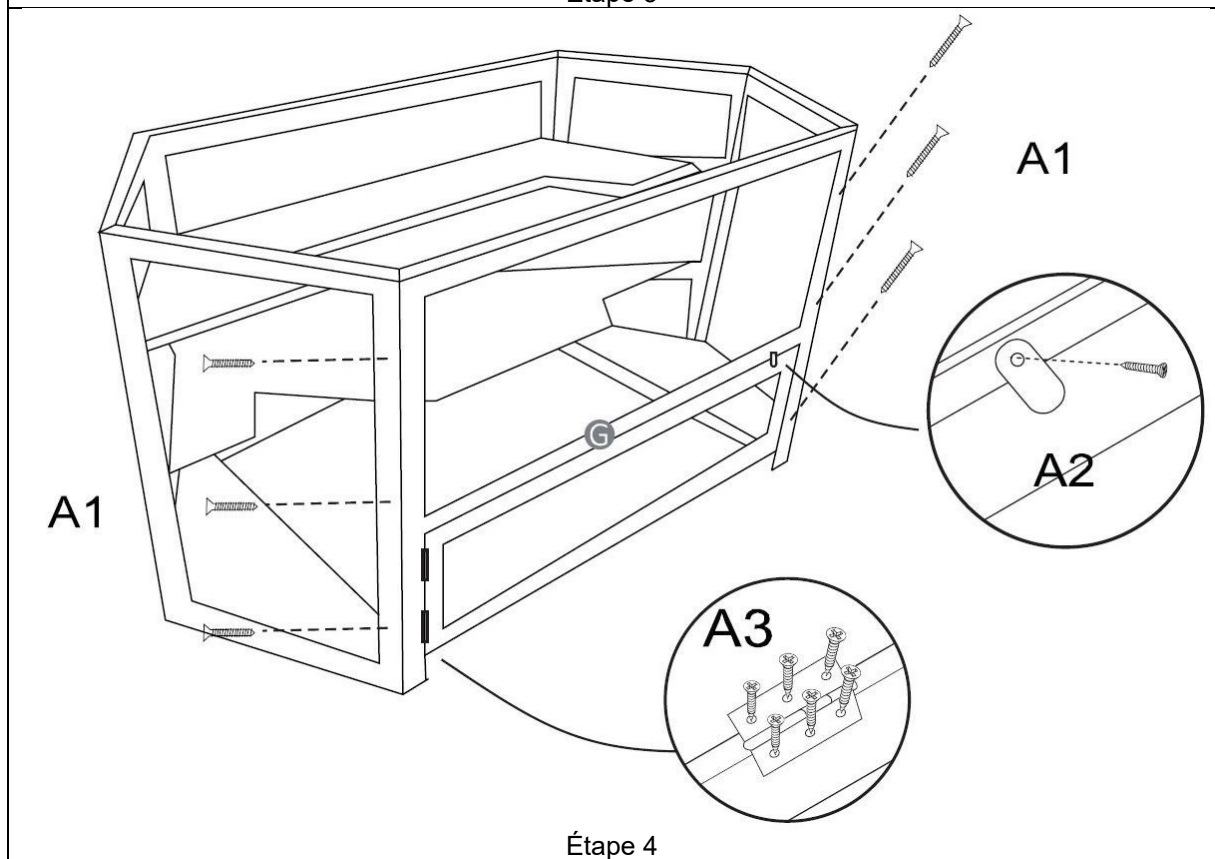
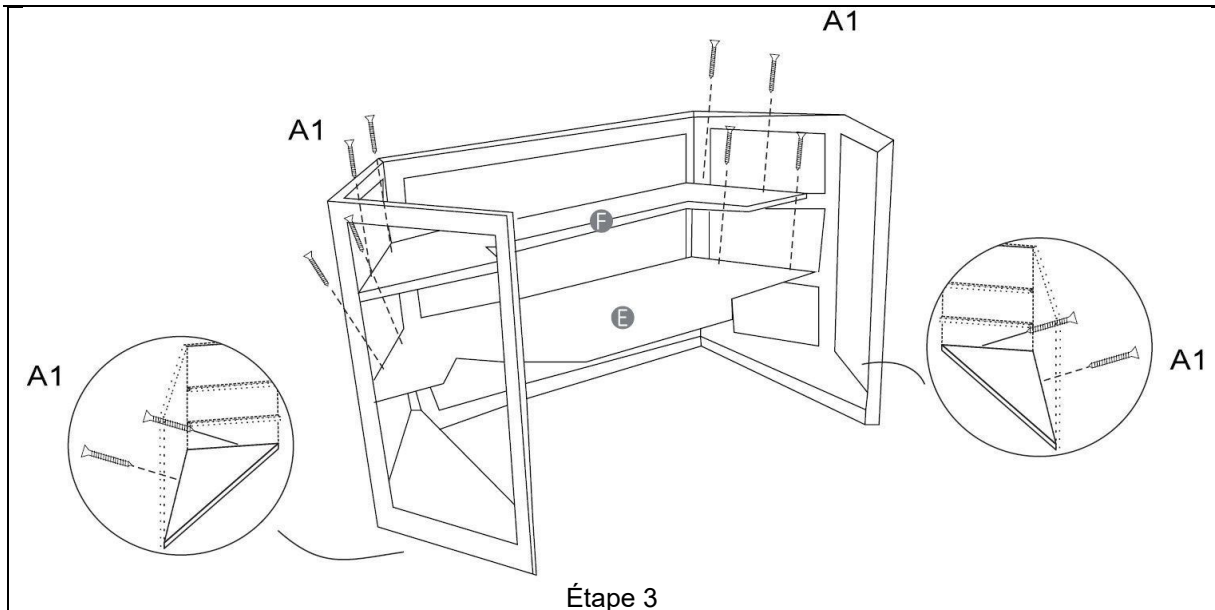

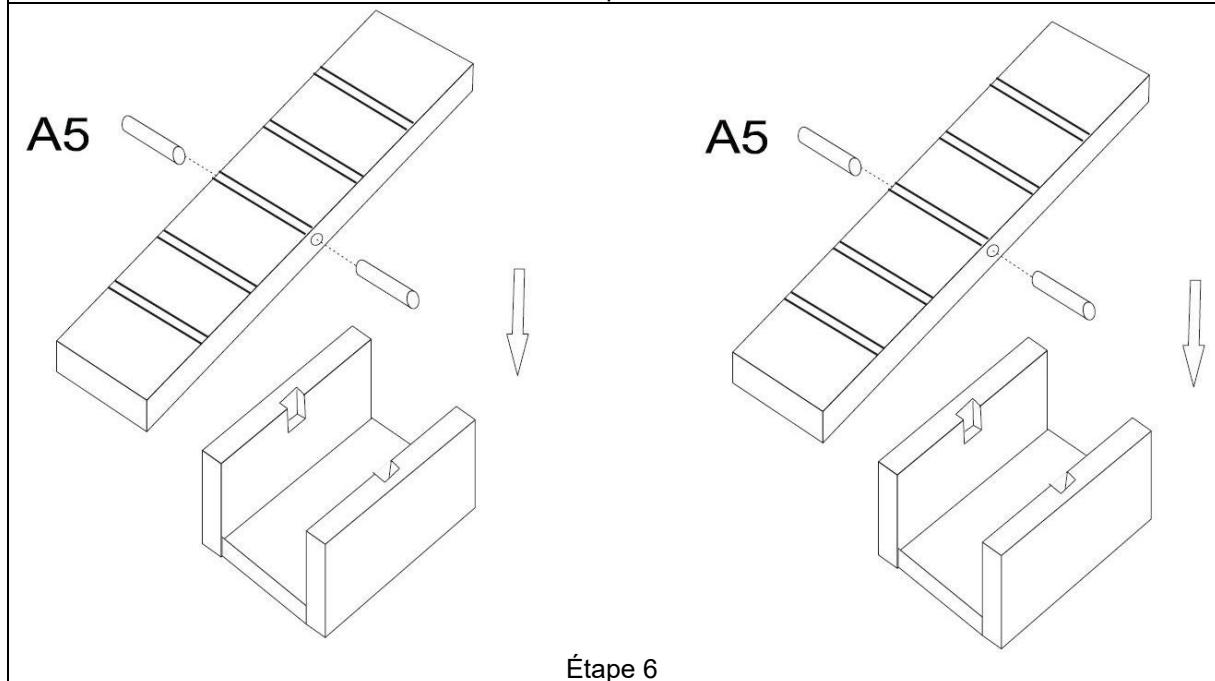
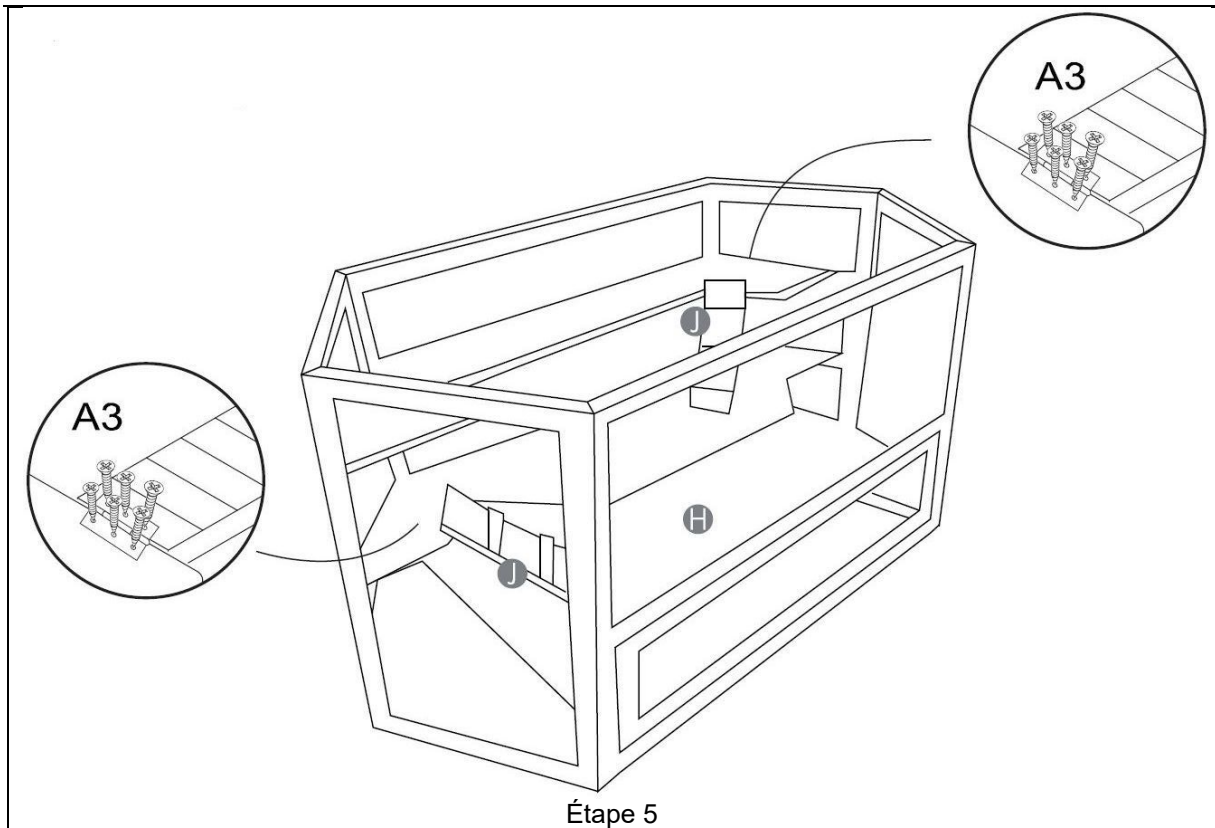

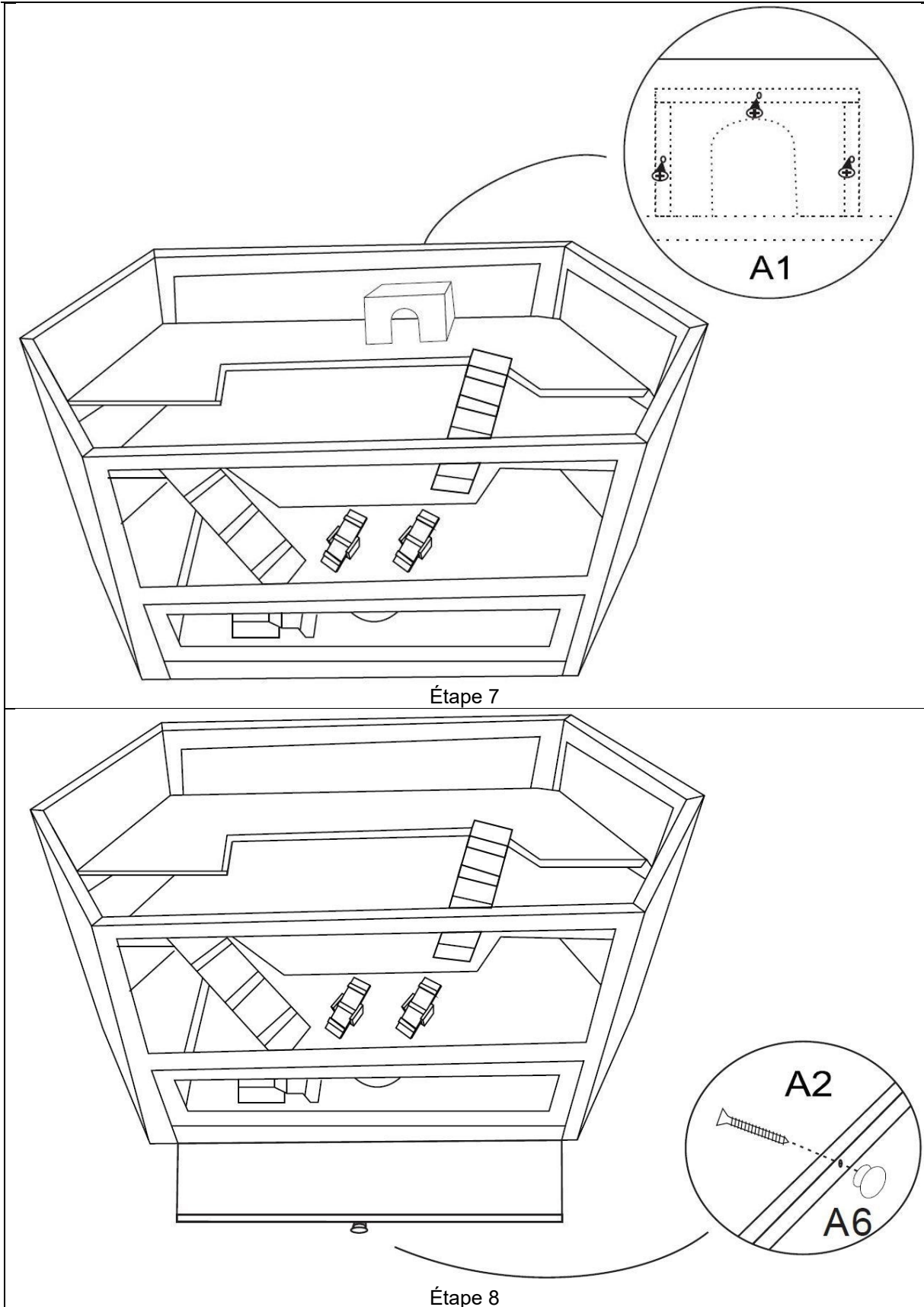

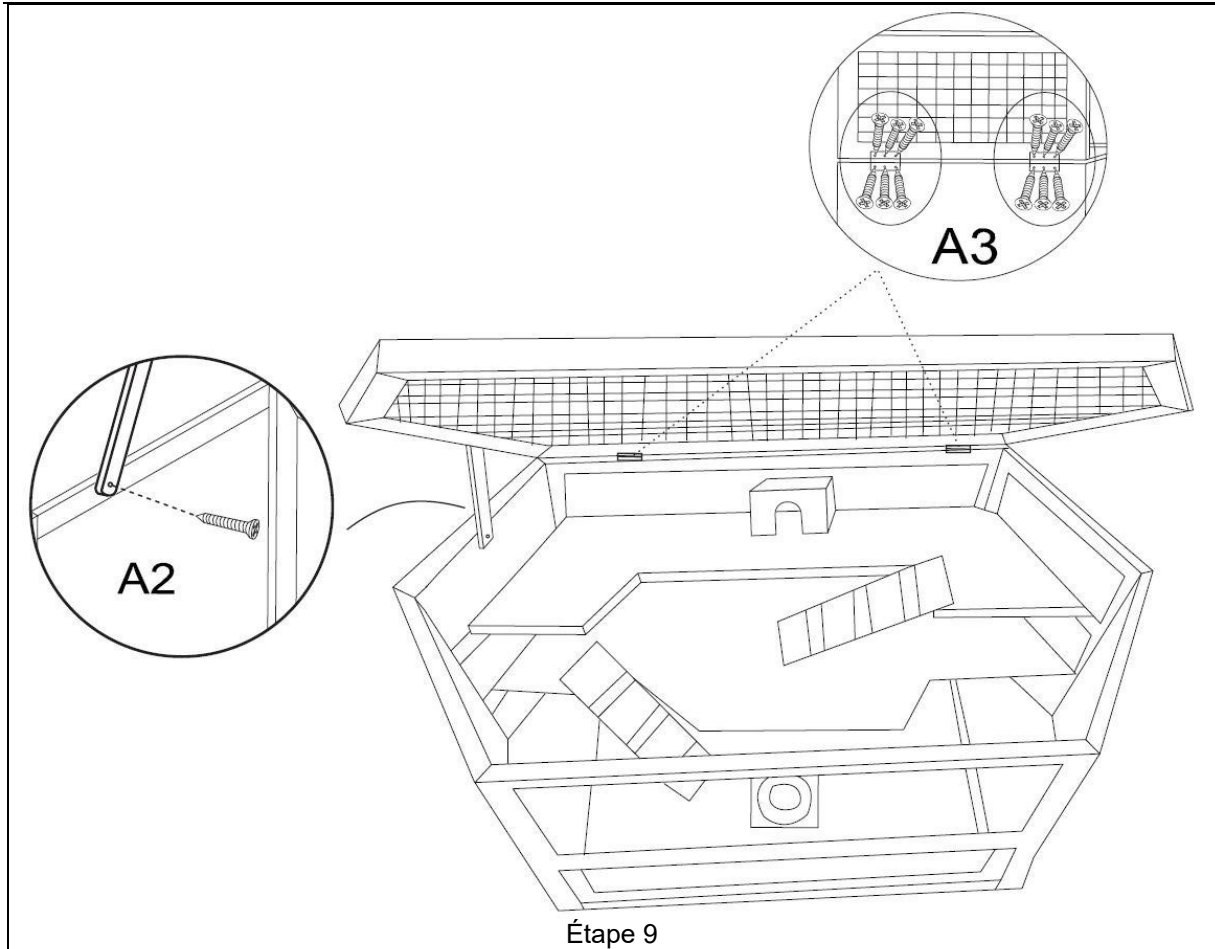

Avis important :

Toute reproduction et toute utilisation à des fins commerciales, même partielle de ce mode d'emploi, ne sont autorisées qu'avec l'accord préalable de la société WilTec Wildanger Technik GmbH.