

Operation Manual

Macerator Toilet Pump System

62138, 62139

wiltec



Illustration similar, may vary depending on model

Read and follow the operating instructions and safety information before using for the first time.

Technical changes reserved!

Due to further developments, illustrations, functioning steps, and technical data can differ insignificantly.

Updating the documentation

If you have suggestions for improvement or have found any irregularities, please contact us.



The information contained in this document may alter at any time without previous notice. It is prohibited to copy or spread any parts of this document in any way without prior written allowance. All rights reserved.

The WilTec Wildanger Technik GmbH cannot be held accountable for any possible mistakes in this operating manual, nor in the diagrams and figures shown.

Even though, the WilTec Wildanger Technik GmbH has undergone biggest possible efforts to ensure that the operating manual is complete, faultless, and up to date, mistakes cannot be entirely avoided.

If you should find a mistake or wish to make a suggestion for improvement, we look forward to hearing from you.

Send an e-mail to:

service@wiltec.info

or use our contact form:

<https://www.wiltec.de/contacts/>

The most recent version of this manual in various languages can be found in our online shop via:

<https://www.wiltec.de/docsearch>

Our postal address is:

WilTec Wildanger Technik GmbH
Königsbenden 12
52249 Eschweiler
Germany

To return orders for exchange, repair, or other purposes, please use the following address. Attention! To allow for a smooth execution of your complaint or return, it is important to contact our customer service team before returning the goods.

Returns Department
WilTec Wildanger Technik GmbH
Königsbenden 28
52249 Eschweiler

E-mail: **service@wiltec.info**

Tel: +49 2403 55592-0

Fax: +49 2403 55592-15



Introduction

Thank you for purchasing this quality product. **To minimise the risk of injury we urge that our clients take some basic safety precautions when using this device. Please read the operation instructions carefully and make sure you have understood its content.**

Keep these operation instructions safe.

Safety instructions



This device is not intended for use by persons (including children) with limited physical, sensory, or mental capabilities or for lack of experience and/or knowledge, unless they are supervised or instructed by a person responsible for their safety how to use this device. Children should be supervised to ensure that they do not play with the device.

General information

The WC lifting unit for waste water consists of the housing, motor, and pump. The pump is suitable for domestic waste water and sanitary facilities. The lifting unit automatically switches the pump on and off depending on the liquid level.

Conditions of use

- The temperature of the medium pumped must not be below 1 °C and must not exceed 80 °C.
- The maximum head is 7 m.

Technical data

Motor power (W)	450
Voltage (V)	230
Frequency (Hz)	50
Current (A)	2
Protection class	IPx4
Max. pressure (bar)	0.7
Max. head (m)	7.5
Flow rate at outlet ($\frac{1}{2}$min)	115
Max. temperature (°C)	< 90
Standard fulfilled	EN-12050-3, EN-12050-4

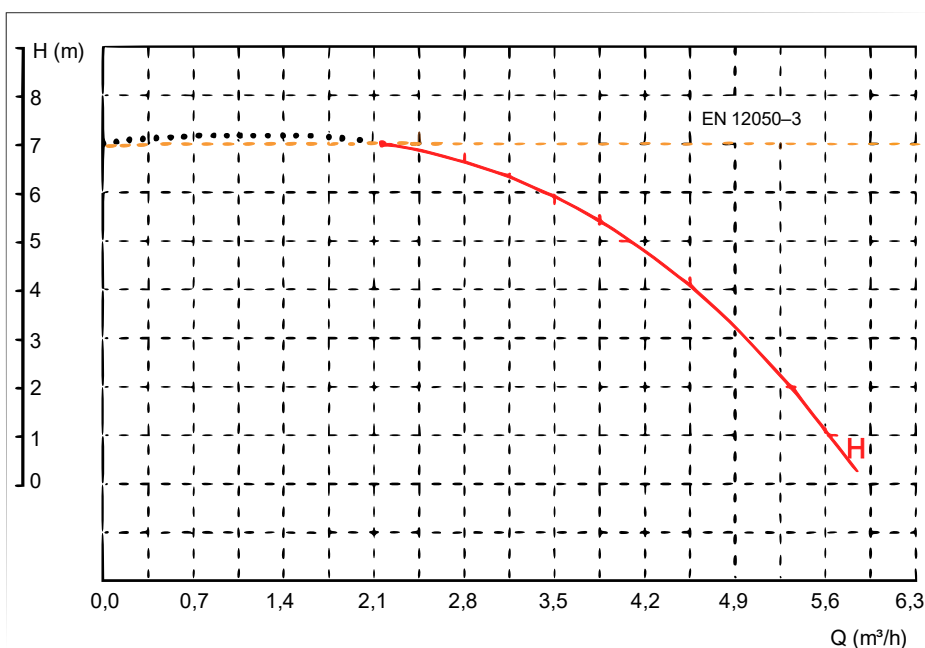
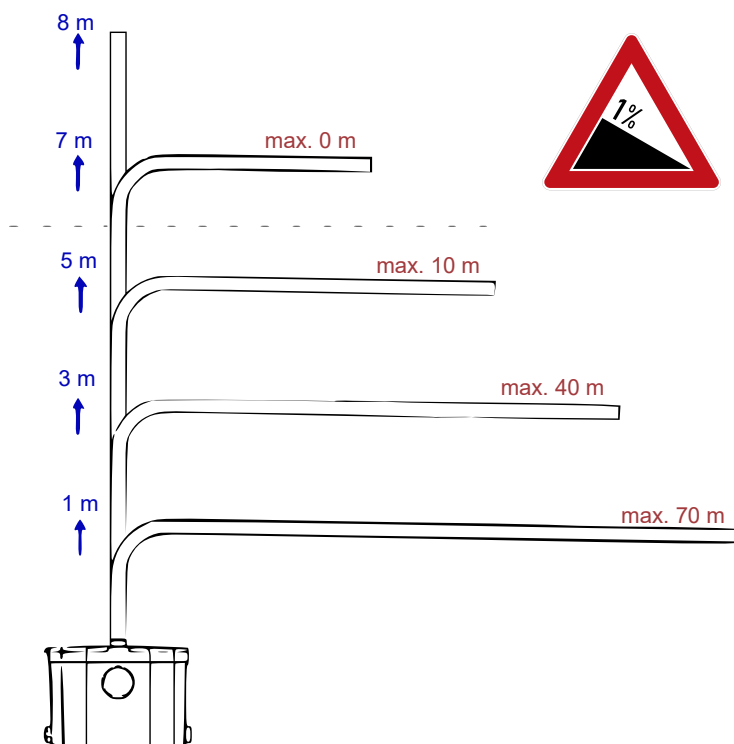

Safety instructions

CAUTION:

On standing waters, garden, and swimming ponds and in their surroundings, the device may only be used with a residual current circuit breaker with a triggering rated current of up to 30 mA (in accordance with VDE 0100 Part 702 and 738).

ATTENTION:

- Carry out a visual inspection of the device before carrying out regular inspections. Do not use the device if safety devices are damaged or worn. Never disable safety devices.



- Only use the device for the purpose specified in these operating instructions.
- You are responsible for safety in the work area.
- If the cable or plug is damaged due to external influences, the cable must not be repaired! It must be replaced with a new one. This work may only be carried out by a qualified electrician.
- The voltage of 230 V (50 Hz) AC specified on the type plate of the device must correspond to the existing mains voltage.
- Never lift, transport, or attach the device to the mains cable.
- Make sure that the electrical plug connections are protected from flood and moisture. Disconnect the mains plug before carrying out any work on the device.
- Avoid exposing the device to a direct jet of water.
- The operator is responsible for compliance with local safety and installation regulations. Ask a qualified electrician if necessary.
- The user must take suitable measures (e.g., installation of alarm system, reserve pump, etc.) to prevent consequential damage caused by flooding of rooms in the event of malfunctions of the device.
- In the event of a failure of the device, repair work may only be carried out by a qualified electrician.
- The unit must never run dry or be operated with the suction line fully closed. The manufacturer's warranty expires for damage to the unit caused by dry running.
- The device must not be used for the operation of swimming pools.
- The unit must not be installed in the drinking water circuit.
- The pumping of aggressive liquids and abrasive materials must be avoided in any case.
- The pump must be protected from frost.
- The pump must be protected against dry running.
- The unit must not be installed in seepage pits or pump shafts.
- The consumers connected to the unit must not be used in the event of power interruptions.
- It is recommended to use a socket only for the unit.
- The device can only dispose of faeces, toilet paper, acidic, fatty, and hot water (up to 80 °C). Avoid throwing inappropriate objects, toiletries, or fibrous material as this may damage the pump.
- Make sure that the consumers connected to the appliance do not have any water leaks, as in this case the pump would operate unnecessarily. In addition, in the event of a power interruption, a water leakage from one of the consumers would cause a water leakage from a device operating below the backwater level.
- If the bathroom or home is not used for a long time, it is recommended to close the main tap.
- This device can be used by children, aged 8, if under observation, or if they receive and understand the instructions relating to safe use of the device with the hazards involved. Cleaning and maintenance by the user should not be performed by children who are not older than 8 years of age and operate under supervision. Keep all power cables out of the reach of children under 8 years of age.
- The equipment may be used by persons with limited physical, sensory, or mental abilities or lack of experience and knowledge if they are supervised, or if they receive and understand the instructions relating to safe use of the equipment with the hazards involved.
- Children should not play with the device.

 **WARNING:**

Read all safety instructions and instructions. Failure to follow the safety precautions and instructions may result in electric shock, fire, and/or serious injury. Keep all safety information and instructions in a safe place for future reference.

Resistance

- To ensure a long service life, only organic toilet waste water, water and paper should be disposed of with the lifting unit.
- The maximum temperature of the pumped liquid should not exceed 80 °C during operation.
- No flammable, gassing, or explosive liquids may be pumped with this pump. This pump must not be used for other liquids, in particular motor fuels, cleaning agents and other chemical products!



Important: Toilet paper, urine and faeces are the only substances that belong in a toilet.
Everything else belongs in the garbage can!

Please note that the waste water can only be pumped into the lifting unit without pressure.

Note: Some of the accessories included in the delivery are located inside the lifting unit. Please remove the accessory bag before installation.

Installation

- The lifting unit will be installed according to EN-12056-4.
- The lifting unit can be operated at any commercially available toilet with a horizontal outlet. According to the EU standard, the centre of the horizontal outlet must be 18 cm above the floor (shell: 18 cm above FFB).
- **Important: PRESSURE-LESS:** When connecting a washing machine to the lifting unit, the waste water hose must not be connected directly to the lifting unit, but must be supplied via a vented pipe system (e.g., via a washbasin which can be slowly introduced into the unit). In case of direct connection, the collecting tank of the lifting unit may burst, and this is **not** a warranty case.
- We recommend that assembly and leak testing be carried out by qualified personnel. Please observe the legal regulations!

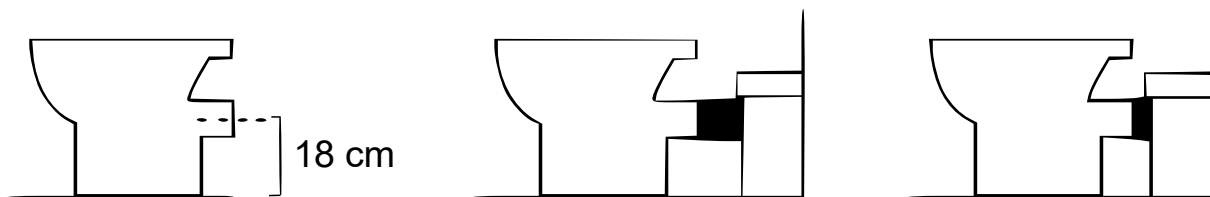

ATTENTION:

During installation, make sure that the pump is not freely suspended from the discharge line or power cable.

Operating principle

- The lifting unit consists of a tank which collects the waste water and an electric pump which is automatically controlled by a pressure switch **(D)**.
- The pumping function is activated when the flush is activated, just like a normal toilet.
- The materials to be conveyed are collected in the container **(A)**. The air chamber **(B)** measures the air pressure flowing through the pipe **(C)** to actuate the pressure switch **(D)**. The pressure switch starts the engine **(E)** that drives the turbine/shredder **(F)**. The waste water is conveyed away through the outlet **(G)**.
- This mechanism is simple and the unit is made of high-quality materials. The function is based on a proven concept.

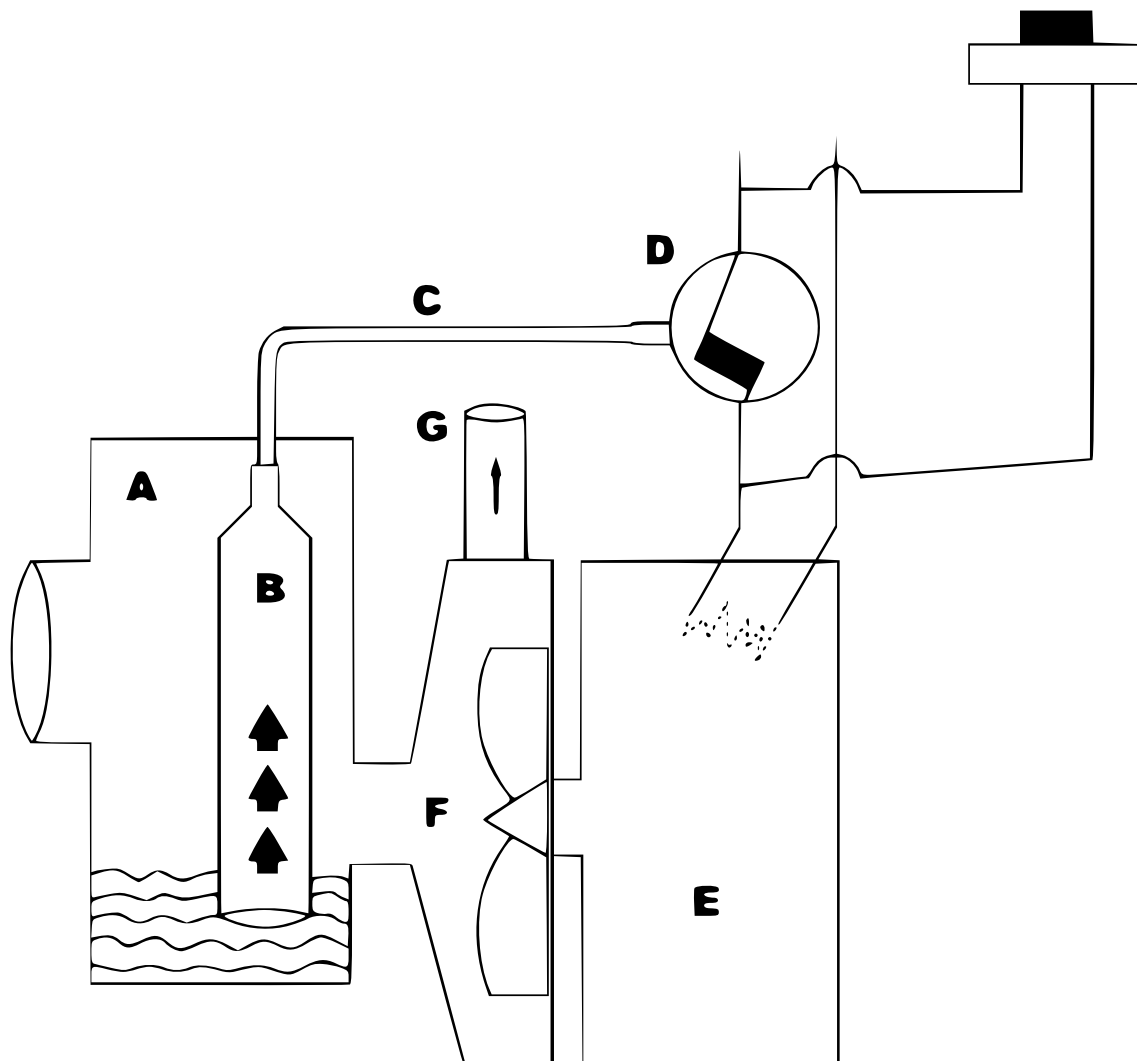

- The lifting unit consists of a housing with a built-in pump which automatically drains acidic, fatty, and hot water (up to 80 °C), faeces and toilet paper via a pipe with a diameter of 23 mm, 28 mm, 32 mm or 44 mm to the next sewage system.
- They are designed to collect waste water from sanitary installations in bathrooms (EN-12050-3, EN-12050-4) or kitchens, including washing machines, dishwashers, and all other appliances whose waste water is to be disposed of (see curve diagram).
- The non-return valve included in the packaging **must** be installed.
- The standard EN-12050-3, EN-12050-4 stipulates that if a WC is connected, only a shower, a bidet and a washbasin can be connected, too.
- The lifting unit cannot be installed on appliances such as washing machines and dishwashers if it is connected to the toilet.
- If the water flow in the tank cannot be interrupted during normal operation, a device with the same capability must be used which will automatically switch on if necessary.
- The installation must comply with the European standard EN 12056-4.
- Fix the container with two plugs (\varnothing 3.5 mm) or a similar device using the fixing holes provided.
- The lifting unit can be connected to any toilet model with a wall drain according to European regulations.
- It is fixed by inserting the WC drain into the rubber sleeve which comes out of the housing and screwing the supplied clamp.

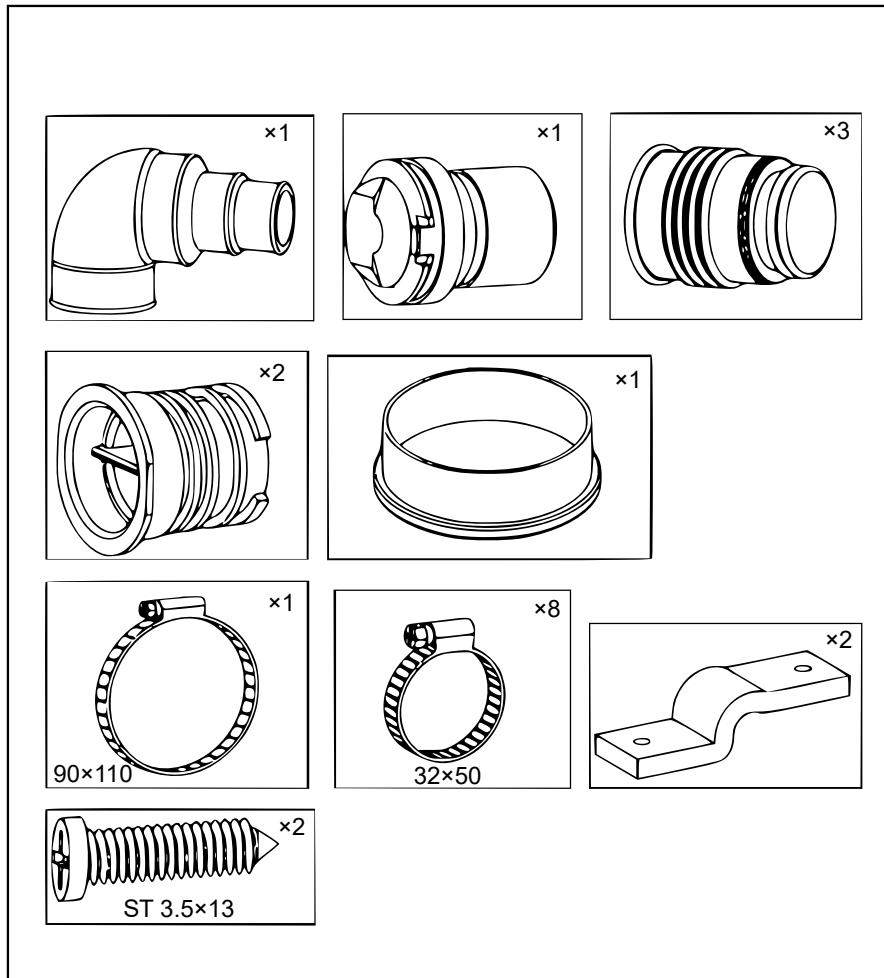

- The connection of the drain is on the top side of the appliance and the other consumers in the bathroom or kitchen are the thin sides of the appliance.
- The connected appliances should be operated separately and not continuously (e.g., shower).
- **N. B.:** The shower and bath drains must be at least 10 cm from the floor. All connected sanitary facilities must be able to interrupt the flow of water.

Minimal height requirements

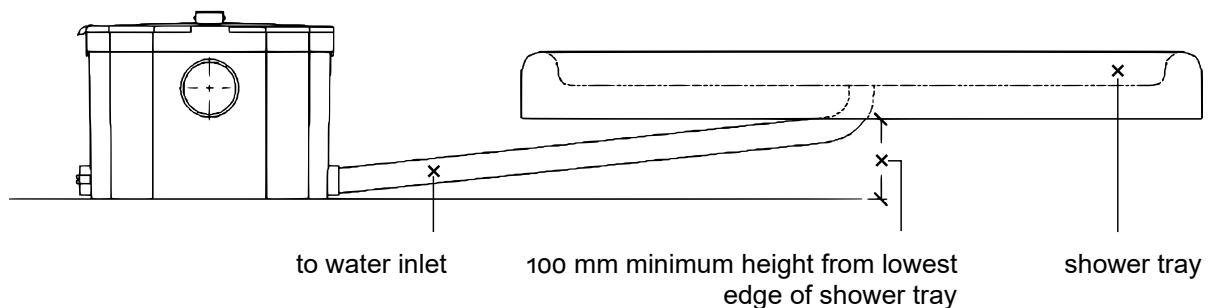

- If the auxiliary inputs are not used, fit the appropriate stopper.

Emptying toilets

- Connect the horizontal outlet of the toilet bowl with the rubber sleeve of the lifting unit and tighten the connection with the supplied clamp. If necessary, use a lubricant to prevent the rubber connection from tearing.
- Connect the drain pipe to the rubber connection piece, the pipe should have a diameter of 40 or 32 mm. Seal the connection with the clamp.

Checking the assembly of the check valve

If the waste water is to be pumped upwards, install the check valve as close as possible to the lifting unit.

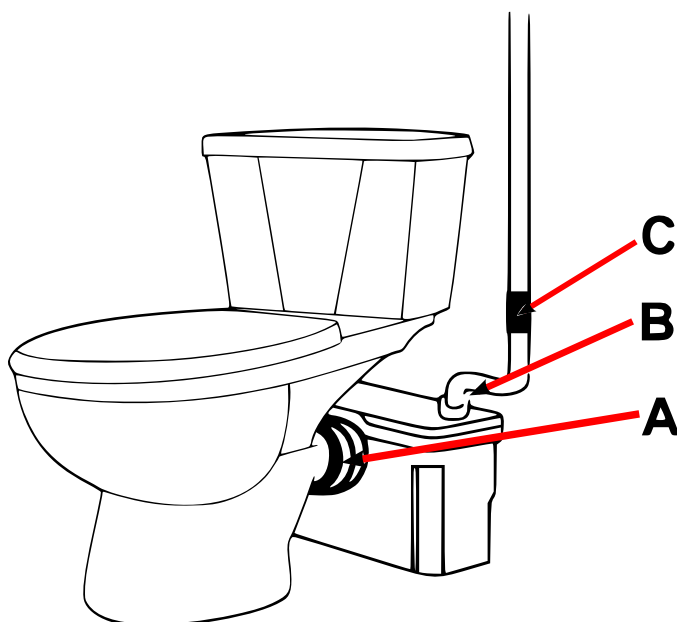

Emptying toilets and other sanitary units

Connect the drain pipes of the other sanitary units with the rubber connectors supplied and tighten them with the clamp. For shower and bath wastewater, ensure that the siphon slope is at least 1% (1 cm/m) so that the wastewater flows to the lifting system by natural gravity.

If other sanitary units are connected along the disposal circuit near the lift, install check valves in the appropriate drain pipes to prevent backflow. The slope of the horizontal components must be at least 1%.

Installation options

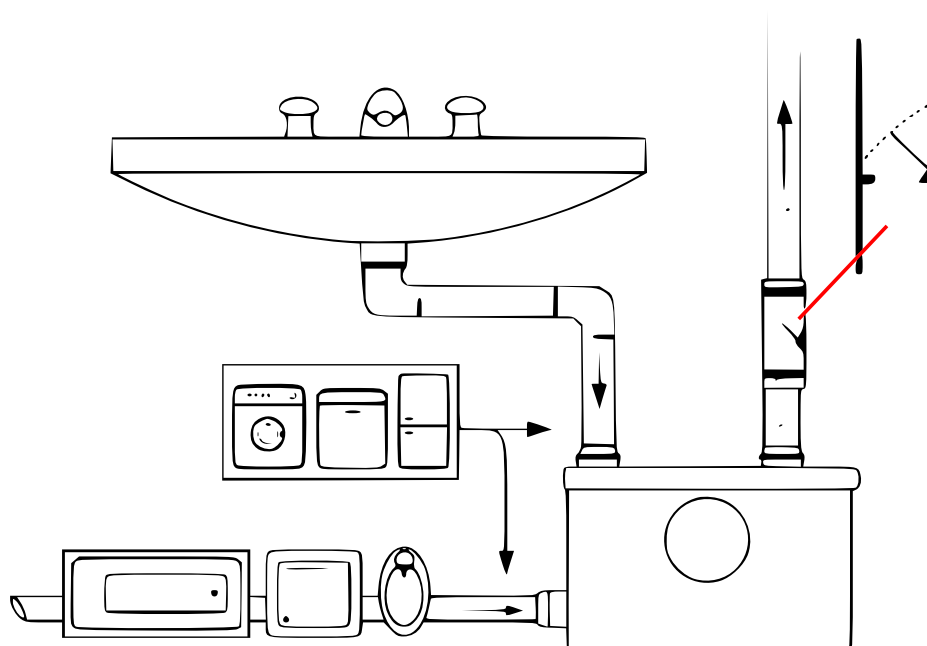



- For the lifting unit to switch on when discharging waste water, the incoming waste water pipe should have a gradient of at least 2–3 % and a height difference of at least 20 cm from the siphon to the inlet to the lifting unit.
- This is both necessary so that the pressure switch in the toilet lifting unit is activated, the lifting unit is switched on and the water is pumped out.
- Possible errors if this is not considered:
 - the lifting system does not pump the water out
 - there is always residual water in the pipes
 - there is residual water in the shower tray.

Maintenance and cleaning

- Read the safety instructions and instructions carefully before opening the unit for maintenance. Maintenance should only be performed on a current-less device.
- The lifting unit consists of a waste water container and a chopper with pressure switch. Both areas are easily accessible through the cover. The maintenance access points are marked on the top of the lifting unit. The maintenance and repair of the device is so comfortably possible.

Removal of foreign bodies and blockages

- Disconnect the mains cable.
- Unscrew the cap with the pump symbol (upper side of the lifting unit).
- Remove the cap.
- Unscrew the cap of the chopping chamber.
- Turn and remove the chopping chamber cap.
- Remove clogging parts (e.g., with pliers).
- When maintenance is complete, reassemble the unit using the reverse procedure.

Troubleshooting

Our devices are suitable exclusively for the disposal of faeces and toilet paper. Some small parts may still be pumped, but larger parts may block the pump. This is the main reason for the incidents recorded by our customer service.

The device is working, but ...	Possible causes	Solution
... does not have enough power or works too slowly to transport the wastewater away.	The drain pipe is too long or too high.	Adjust the arrangement of the pipes.
	The diameter of the drain pipe is too small.	Use a different pipe.
	A part is clogged.	Start the pump with the manual switch button. If the problem persists, the pump must be blocked.
... a buzzing noise sounds, but the sewage is not being transported away.	The pump is blocked.	Check the pump impeller for blockage when the mains plug is unplugged.
	The non-return valve has been mounted the wrong way round.	Mount the non-return valve in the correct direction.
... is launched in unintended manner.	The check valve is defective.	Check the non-return valve.
	A leak in the cistern ensures that water flows into the lifting system and from time to time triggers the transport process.	Repair the cistern or water source.



... runs permanently	The vertical outlet does not have a non-return valve.	Mount a non-return valve.
	The check valve is defective.	Check the non-return valve and replace the defective valve.
	The pressure switch is defective.	Check the pressure switch – a pressure switch that is wet or full of water is defective – the line to the pressure switch must be dry.
... there is no humming sound.	The power connection is defective.	Check the power connection.
	Pressure switch or motor defective or blocked	Check the current connection of the pressure switch and the line of the pressure switch (see description). Check the motor or pump impeller for blockage.

Detailed error descriptions and solutions

Residual water in the shower tray

For the lifting unit to switch on cleanly when discharging waste water, the incoming waste water pipe should have a gradient of at least 2–3 % and a height difference of at least 20 cm from the siphon to the inlet to the lifting unit.

This is both necessary for the pressure switch in the toilet lift to work properly, turn on the lift and pump out the water. Possible faults, if this is not considered, are that the lifting unit does not pump the water out or that there is always too much left in the pipes or possibly in the shower tray.

Loud noises, motor does not start or starts heavily, water is not pumped out.

These symptoms occur when the lifting system is blocked.

If the system is clogged with toilet paper and faeces, in most cases it is sufficient to carefully flush the system backwards with water. To do this, simply apply a little water pressure to the outlet of the lifting unit, e.g., with a garden hose, so that the residues from the pump body are flushed back into the lifting unit. Please make sure that there is no water pressure on the collecting tank of the lifting unit. Otherwise, the pressure switch of the lifting unit will be damaged and the automatic on/off switch will no longer function correctly.

In the case of heavy blockages/blockages caused by solids which have jammed in the pump body, it may be necessary to open the pump so that the solids can be removed.

Strong impacts from the solids in the lifting unit may even damage the motor bearings. In this case, the motor of the lifting unit must be opened and the bearing replaced. This fault usually manifests itself after the removal or rinsing out of larger solids. The lifting unit can then still be turned freely by hand, but as soon as you try to start the engine, it blocks and only hums.

Cleaning can easily be done through the maintenance opening on the top of the lifting unit.

Lifting unit does not pump down and is in continuous operation

This error occurs in lifting systems that were switched off (no power) and still had inlet, or where sewage was discharged under pressure from a dishwasher or washing machine, or that had more inlet than the pump could pump out. As a result, the systems were “overfilled.”



It can then happen that water gets into the pressure switch of the lifting unit. This disturbs the function of the pressure switch. The system then either runs continuously or no longer switches on automatically.

Cleaning the unit

The lifting unit may only be cleaned from the outside with mild detergents, a damp cloth and soapy water. Damage caused by incorrect cleaning agents is not covered by the warranty.

Disposal regulations

EU guidelines regarding the disposal of scrap electric appliances (WEEE, 2012/19/EU) were implemented in the law related to electrical and electronic equipment and appliances.

All WilTec electric devices that fall under the WEEE regulations are labelled with the crossed-out wheeled waste bin logo. This logo indicates that this electric equipment must not be disposed with the domestic waste.

The company WilTec Technik GmbH has been registered in the German registry EAR under the WEEE-registration number DE45283704.

Disposal of used electrical and electronic appliances (intended for use in the countries of the European Union and other European countries with a separate collection system for these appliances).

The logo on the article or on its packaging points out that this article must not be treated as normal household waste but must be disposed to a recycling collection point for electronic and electrical waste equipment. By contributing to the correct disposal of this article you protect the environment and the health of your fellow men. Environment and health are threatened by inappropriate disposal.



Material recycling helps reduce the consumption of raw materials.

Additional information on recycling this article can be provided by your local community, municipal waste disposal facilities, or the store where you purchased the article.

Address:
 WilTec Wildanger Technik GmbH
 Königsbenden 12 / 28
 D-52249 Eschweiler

Important notice:

The reprint or reproduction, even of excerpts, and any commercial use, even in part, of this instruction manual require the written permission of WilTec Wildanger Technik GmbH.