

Operation Manual

Ground Drill (2-persons operation)

62350, 62351, 62650–62663



Illustration similar, may vary depending on model

Read and follow the operating instructions and safety information before using for the first time.

Technical changes reserved!

Due to further developments, illustrations, functioning steps, and technical data can differ insignificantly.

Updating the documentation

If you have suggestions for improvement or have found any irregularities, please contact us.



The information contained in this document may alter at any time without previous notice. It is prohibited to copy or spread any parts of this document in any way without prior written allowance. All rights reserved.

The WilTec Wildanger Technik GmbH cannot be held accountable for any possible mistakes in this operating manual, nor in the diagrams and figures shown.

Even though, the WilTec Wildanger Technik GmbH has undergone biggest possible efforts to ensure that the operating manual is complete, faultless, and up to date, mistakes cannot be entirely avoided.

If you should find a mistake or wish to make a suggestion for improvement, we look forward to hearing from you.

Send an e-mail to:

service@wiltec.info

or use our contact form:

<https://www.wiltec.de/contacts/>

The most recent version of this manual in various languages can be found in our online shop via:

<https://www.wiltec.de/docsearch>

Our postal address is:

WilTec Wildanger Technik GmbH
Königsbenden 12
52249 Eschweiler
Germany

To return orders for exchange, repair, or other purposes, please use the following address. Attention! To allow for a smooth execution of your complaint or return, it is important to contact our customer service team before returning the goods.

Returns Department
WilTec Wildanger Technik GmbH
Königsbenden 28
52249 Eschweiler

E-mail: **service@wiltec.info**

Tel: +49 2403 55592-0

Fax: +49 2403 55592-15



Introduction

Thank you for purchasing this quality product. **To minimise the risk of injury we urge that our clients take some basic safety precautions when using this device. Please read the operation instructions carefully and make sure you have understood its content.** Keep these operation instructions safe.

General information

Warning: If used correctly, this ground drill is a fast and powerful tool. However, inappropriate use turns this tool into a source of danger. Therefore, make sure to abide by the instructions and information stated within this operation manual to guarantee a safe and efficient operation.

Carefully read this operation manual, make sure to fully understand it and store it in a safe and dry environment to be able to access it at any point in time. Non-compliance with the stated instructions or careless use of the device may lead to property damage and serve injuries.

Important: This operation manual contains information that must be abided by to prevent the device from malfunctioning and being damaged.

Warnings found on the device



Caution! Fire hazard!



Wear ear protection.



Caution! Hot surfaces!



Read the operation manual.



Caution! Toxic gas!

Safety instructions

- The ground drill may only be used by individuals that have read this operation manual and are familiar with the device.
- This device must not be used by children or individuals with reduced physical, sensory, or mental capabilities, or lack of experience and/or knowledge. Children should be always supervised to ensure that they do not play with it.
- Do not operate the device while being exhausted, tired or under the influence of alcohol, drugs, or medicine.
- Do not wear loose clothing or accessories, which could be gripped by the moving parts of the drill. Long hair must be tied up or covered with a snood-type cap, and protective clothes should be worn.



- Always wear anti-skid shoes, work gloves, safety goggles as well as ear protection while operating the device.
- Ensure that bystanders are kept away from the working area while the device is in use. Distractions might lead to loss of control and cause severe accidents.
- Before the begin of the operation, make sure that the working area is clear. Do not drill in the immediate vicinity of cables or pipelines.
- The ground drill is equipped with a combustion motor and must therefore be used in well ventilated areas and must be kept away from flammable or explosive substances.
- Only lift or carry the device, if it has been turned off and the auger stopped moving.
- Immediately replace the auger, if the same shows visual or acoustic signs of damage or wear.
- Only use two-stroke mixture with an appropriate petrol and oil mixing ratio of 30:1 to fuel the device. Do under no circumstances use pure petrol or any other kind of fuel.
- Only start refuelling the device after its motor has been turned off and be careful to avoid the contact between fuel and hot surfaces of the device. Do not smoke during the process of refuelling and make sure to keep any kind of ignition source away from the working area.
- Only open the fuel tank cap while the motor is turned off and make sure to close it properly before turning it on again.
- Always keep the handles dry and clean to minimise the risk of loss of control.
- Always check the auger for visible signs of damage and make sure moving parts are not deformed or obstructed before operating the device.
- Only use the ground drill, if a secure footing is ensured.
- Do not touch the running motor of the device and never attempt to exchange a running motor.
- The auger is not allowed to rotate while running in idle mode.
- Always use both hands to operate the ground drill to ensure a maximum of control over the device.
- Stay away from the Auger and the exhaust pipe of the drill while in operating it.
- Do not perform maintenance exceeding the superficial procedures and care. In-depth maintenance and repairs may only be performed by qualified personnel.
- Always store the ground drill within a dry environment inaccessible to children. Make thereby sure that its fuel tank is empty, that it is placed in a vertical position and not touching the ground.
- Check the device for damage or malfunctions before using it.
- When changing holes, make sure the ground drill is running in idle mode and the auger is not rotating.
- Do not use defect, modified or provisionally repaired devices and only use augers suitable for the device.
- Never touch the spark plug or spark plug wire while the motor is operating. Touching either of them while the motor is running carries the risk of electric shock.
- Do not operate the ground drill unless this operation manual has been read and understood and its users have familiarised themselves with the device, its functions, and fields of application.
- Before and after using the motor, let the device operate at low speed and without load for 2–3 min. Do not use the device at full speed unless drilling with full load and never jerk the device to halt when using it with higher speed settings.
- Do not touch the motor or the carburettor while or shortly after operation. Non-compliance bears the risk of burns.
- The device can only be disposed of at an official dumpsite or collection station. The device must not be put into the domestic refuse.
- Clean and maintain the device on a regular basis and only use suitable spare parts of equal quality.

Technical specifications

Gearing	Reduction gear ratio	40:1
	Type	Double gearbox
	Transmission mode	Centrifugal clutch
	Auger size diameter (cm)	8 / 10 / 15 / 20 / 25/ 30
Motor	Type	Air-cooled two-stroke engine
	Maximum output (kW / 1/min)	2.8 / 9000
	Capacity (mℓ)	63.3
	Idling speed (1/min)	2800 ± 150
	Coupling (1/min)	3950 ± 150
	Ignition type	Electric ignition (CDI)
	Ignition system	Magneto
	Carburettor type	Membrane
	Fuel	Two-stroke mixture (Petrol:Oil = 30:1)
	Fuel tank volume (ℓ)	1.45

Assembly

1. Remove the device from its box and place it on the ground. Remove the nuts (**Fig. 1, A**) as well as the two screws (**Fig. 1, B**) from the connection plate.
2. Turn the right handle (**Fig. 2, C**) downward as depicted in fig. 2 and keep moving it until it reaches the position shown in fig. 3.

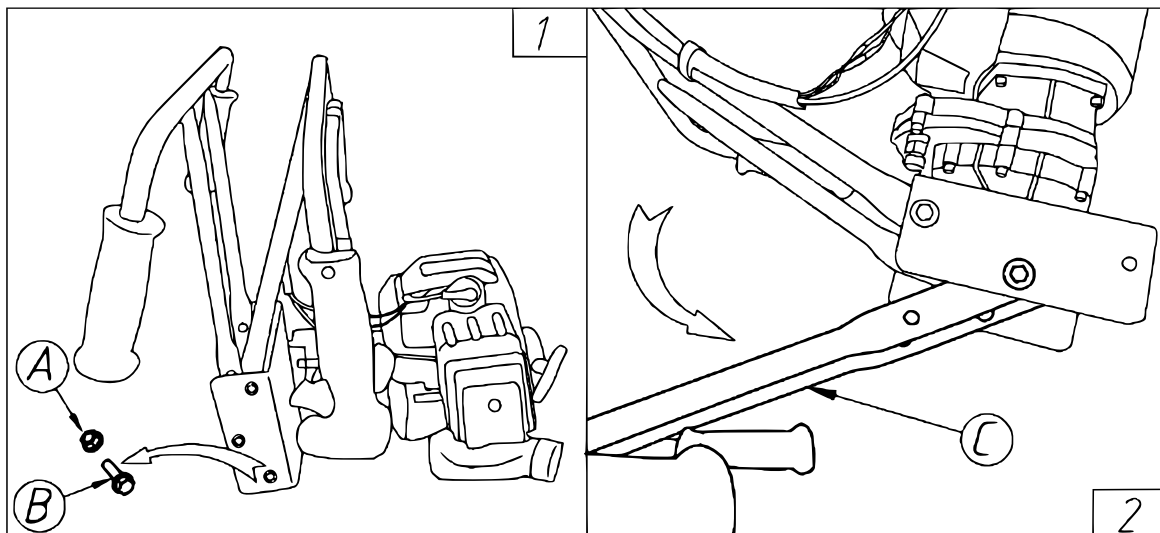

3. Bring the handle bars into their operating positions by unfolding them and lock them in place by screwing them to the connecting plate (**Fig. 3**) using the screws and nuts that were previously removed.

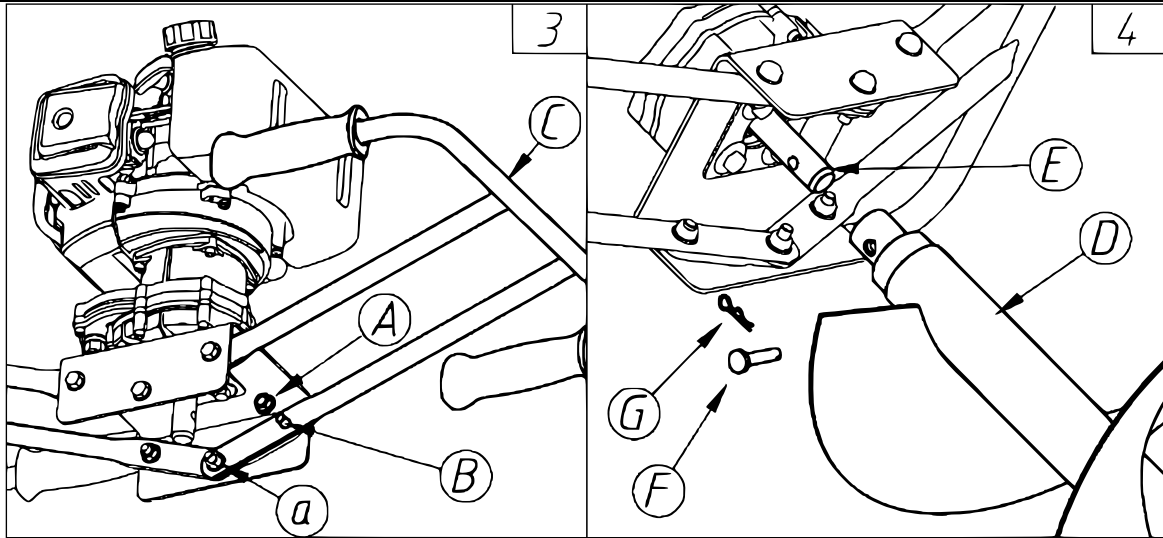

4. Connect the auger (**Fig. 4, D**) to the device by placing it onto the shaft (**Fig. 4, E**) and secure it with the help of the bolt (**Fig. 4, F**) and the cotter pin (**Fig. 4, G**).

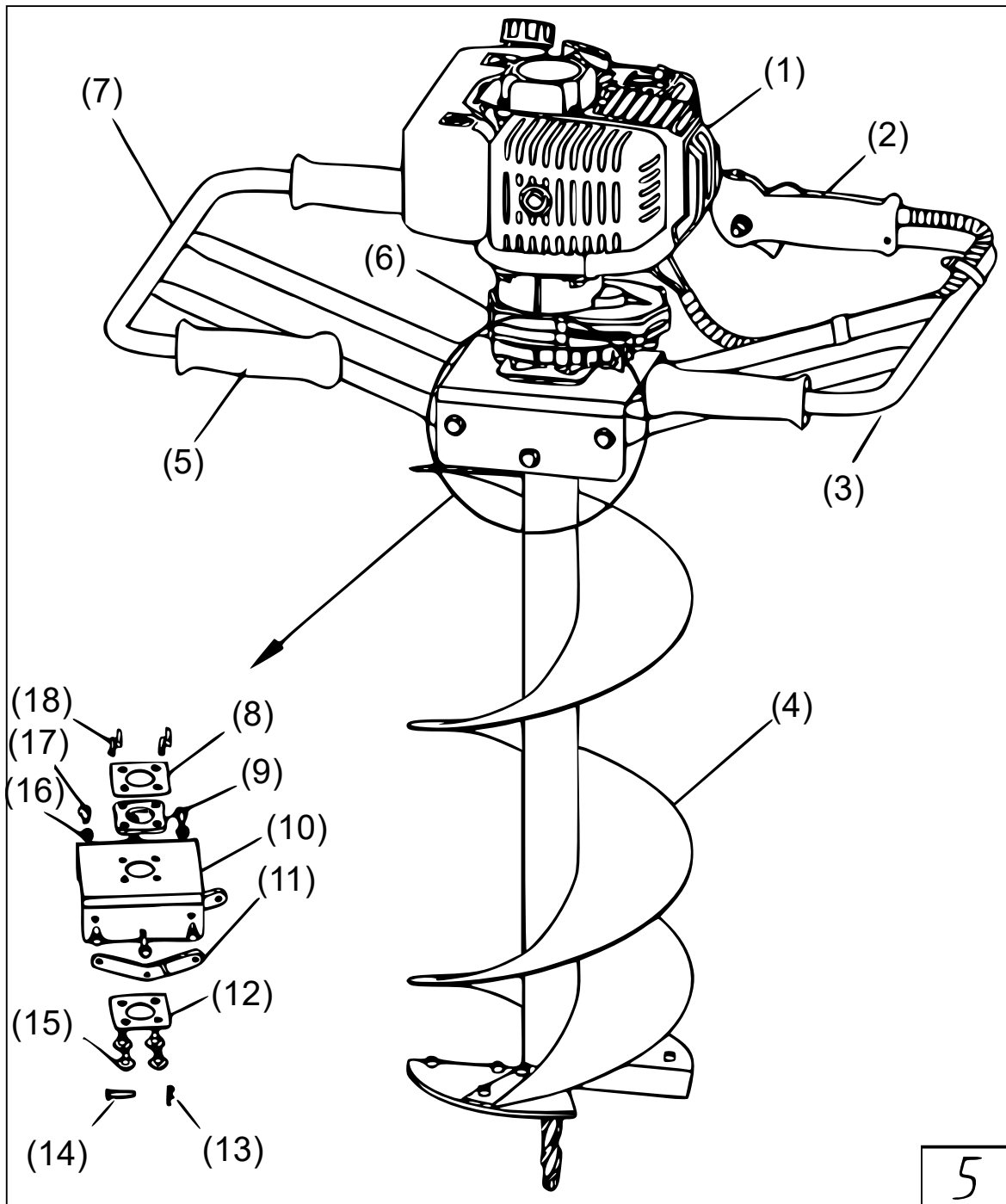

No	Name	No	Name	No	Name
1	Motor	7	Left handle bar	13	Cotter pin
2	Control handle	8	Base plate	14	Bolt
3	Right handle bar	9	Gasket	15	Screw
4	Auger	10	Connecting plate	16	Nut
5	Handle	11	Fixture	17	Screw
6	Gearbox	12	Base plate	18	Screw

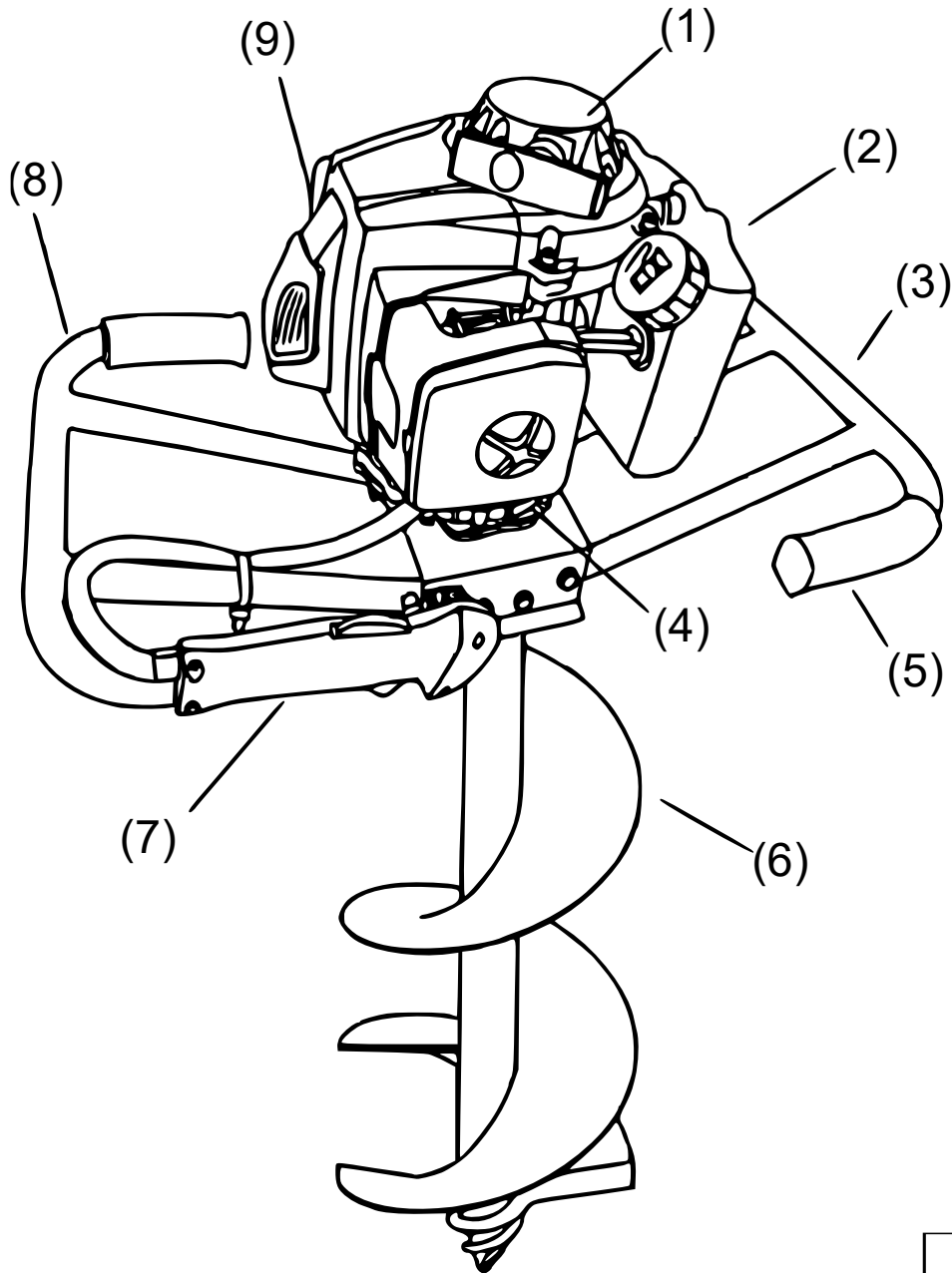

6

Nº	Name	Nº	Name
1	Starter	6	Auger
2	Fuel tank	7	Control handle
3	Left handle bar	8	Right handle bar
4	Gearbox	9	Motor
5	Handle		

Getting started

Fuel mixing ratio

As depicted in fig. 7, the device must be fuelled with two-stroke mixture with a petrol oil ratio of 1:30.

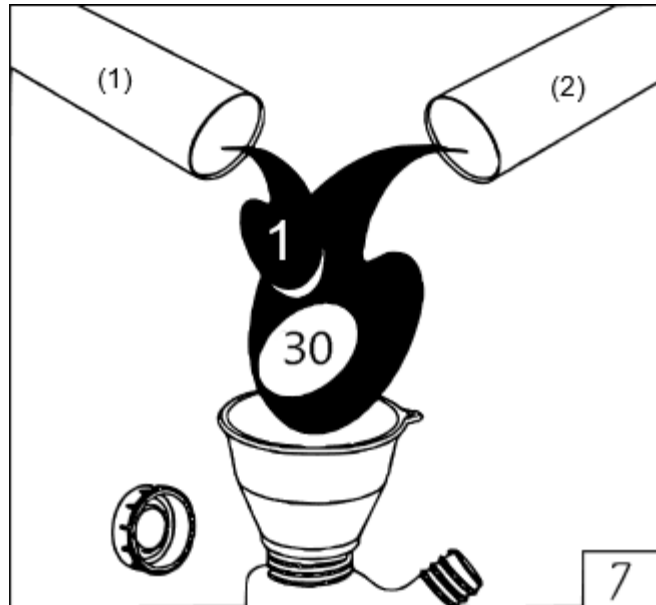

No	Name	No	Name
1	Two-stroke oil	2	Petrol (90 Octane)

Warning: Two-stroke engines are designed to operate with normal petrol. Therefore, make sure to only use normal petrol and premium grade petrol with a minimum octane rating of 90 and oil specifically designed for two-stroke engines. Mix the two liquids before pouring them into the motor and ensure that the liquids have intermixed with each other before carefully inserting the fuel into the motor (**Fig. 8**).

Never fill the fuel tank while the motor is operating and instead ensure that the motor has been turned off before placing the device on an even ground in order to prevent two-stroke mixture from spilling in the process.

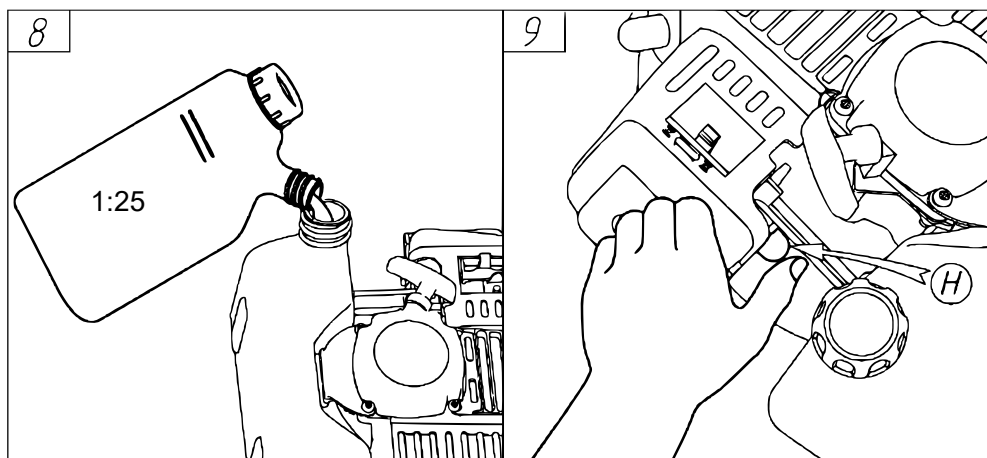

Important! When storing the device, make sure that the fuel has been drained completely. Do not use the device, if fuel should be leaking.

Starting the motor

1. Bring the switch located on top of the control handle (**Fig. 11, K**) into the “Start” position.
2. Next press both the security switch (**Fig. 11, L**) and the throttle lever (**Fig. 11, M**). Lock them in place by pressing the interlock (**Fig. 11, N**).
3. Once the interlock (**Fig. 11, N**) has been used, let go off the security switch (**Fig. 11, L**) and the throttle lever (**Fig. 11, M**)

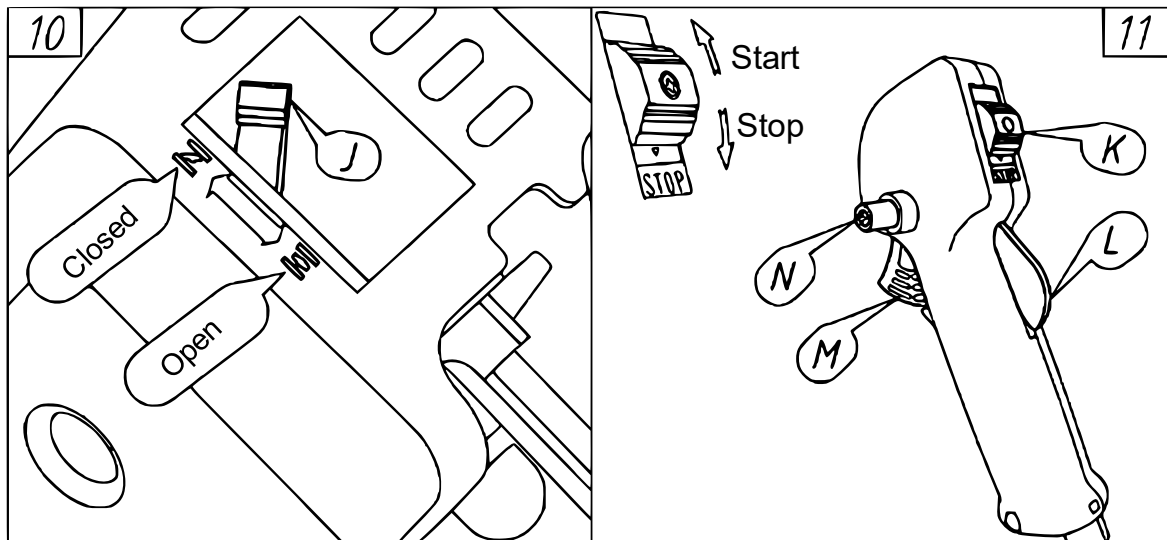

4. Set the inductor switch (**Fig. 10, J**) to “Open.”
5. Repeatedly press the primer (**Fig. 9, H**) to pump fuel into the system.
6. Repeatedly pull the rope start until the motor starts running.
7. Set the inductor switch (**Fig. 10, J**) back to the “Closed” position.
8. Once the motor is operating, press the throttle lever (**Fig. 11, M**) to unlock the interlock (**Fig. 11, N**) and allow the device to run in idle mode.

Notes: Do not use the inductor if the engine is already warm. The inductor is only used to perform cold starts. Also, the auger must not rotate while the motor is operating in idle mode.

Warning note: The motor must be stopped immediately, if the auger should deform or break.

Note: When using the rope start:

- Do not let the rope rebound.
- Do not pull the rope as far as it will go, since this will damage the rope start.
- Always let the rope slide back slowly to allow it to roll up properly.

Switching off the Motor

1. Place the throttle lever (**Fig. 11, M**) in idle position and let the device run in idle mode for 2–3 min to allow the motor to cool down.
2. Turn the motor off by setting the switch (**Fig. 11, K**) to “stop.”
3. Remove the auger from the device and clean both.

Important: Do not jerk the device to halt while it is running with full load as this might damage the device.

Maintenance

Air filter

The air filter should be cleaned after every 25 hours of operation. For the air filter (**Fig. 12/13, R**) to be cleaned, the air filter casing (**Fig. 12–13, Q**) must be removed. Use petrol to clean the filter and let it dry.

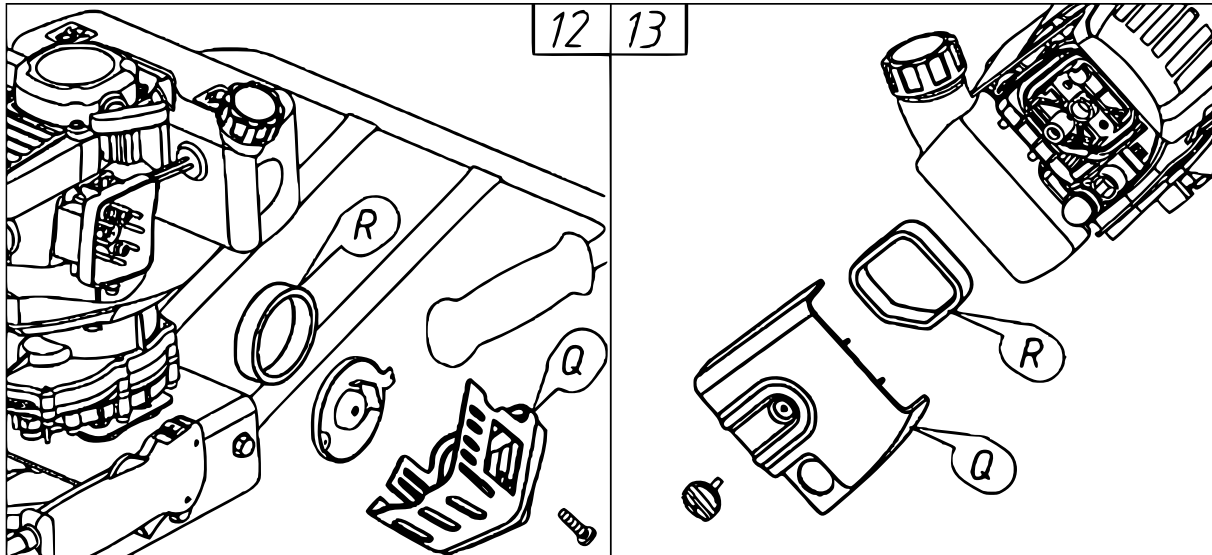

Carburettor

The carburettor is a very important component of the device. Its settings (such as mixing ratio and idling drive power) have been pre-set by the manufacturer and should not be changed. Please note that weather conditions as well as altitude may influence the functions of the carburettor.

Petrol filter

Make sure to regularly check the petrol filter (**Fig. 14, U**) and replace it immediately, in case of it being heavily polluted. A polluted petrol filter may cause issues while starting the device as well as a loss of performance.

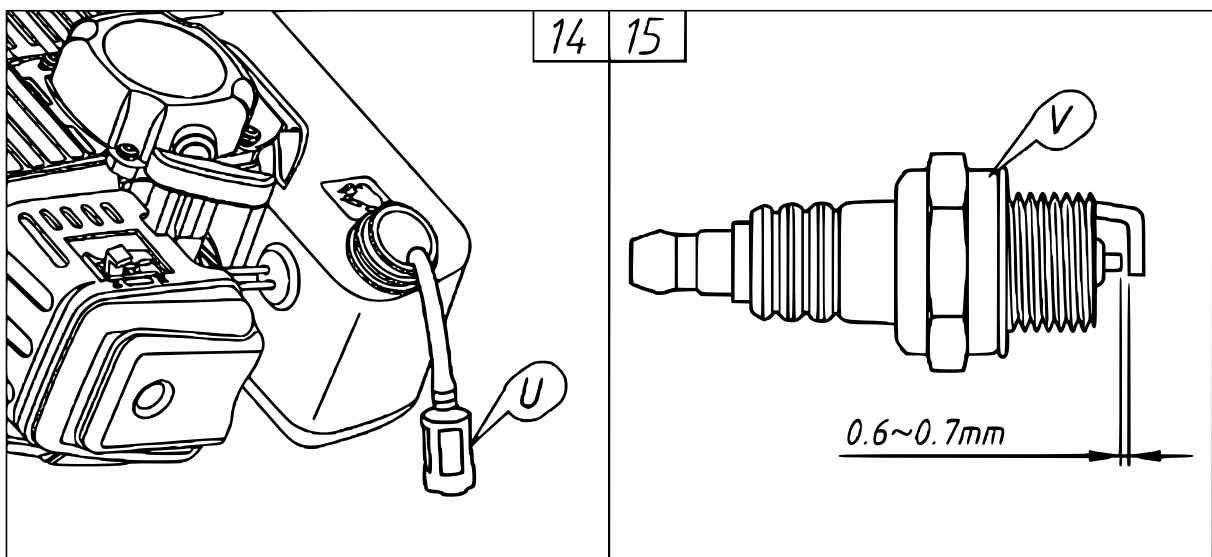

Motor

Make sure to regularly clean the cylinder fins with air pressure or a brush. Polluted cylinder fins severely affect the internal cooling system of the motor and might damage it.

Spark plug

Remove the spark plug wire and unscrew the spark plug. Clean both, the spark plug as well as the spark plug wire, if dirt should have accumulated. Sand the electrode with sand paper and set the distance of the electrode to 0.6–0.7 mm (**Fig. 15, V**).

Auger

Check the condition of the auger before every use and sharpen or replace it, if necessary. Always make sure to choose the auger according to the requirements of the task at hand (**Fig. 16**).

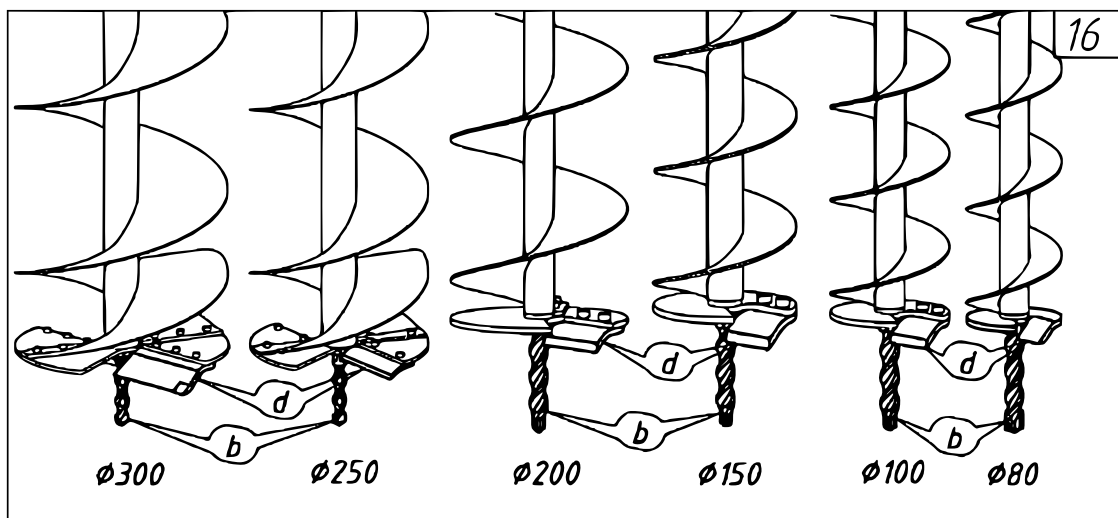

Reduction gear

If used normally, the valve cap (**Fig. 17, W**) must be checked and cleaned after every 50 hours of operation. Every 100 hours of operation, the gear grease must be exchanged (**Fig. 17, 1; 180 g**).

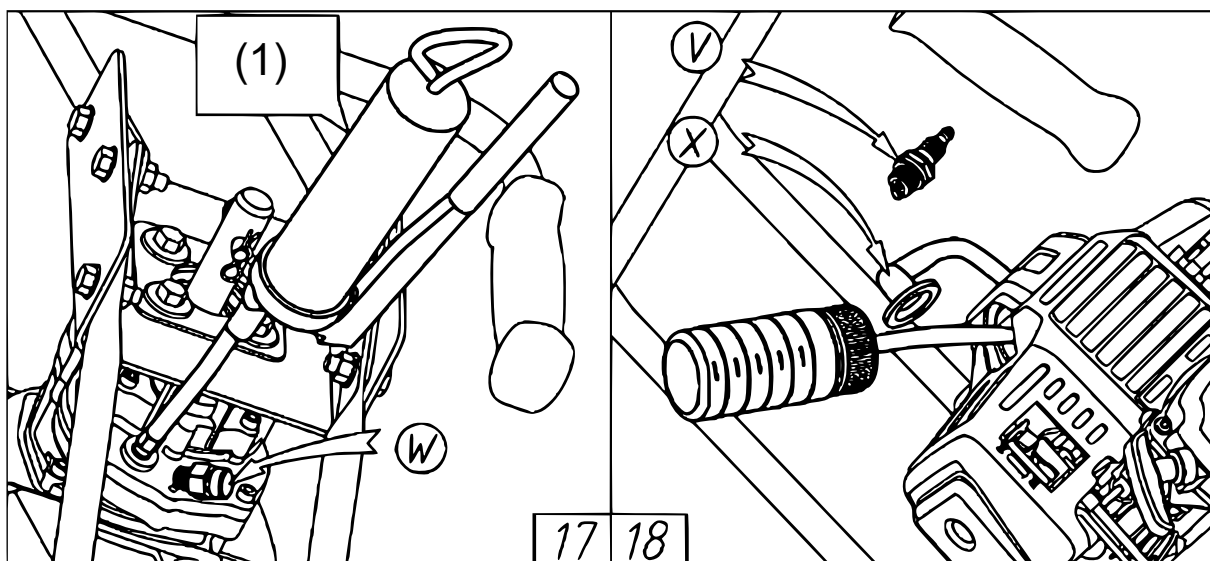



Storage

- Always perform maintenance in accordance with the previously stated maintenance steps.
- If the ground drill should be stored for longer periods of time, make sure to clean it thoroughly and to grease all metal parts to prevent corrosion.
- Remove the auger from the device and clean and lubricate both components to prevent rust.
- Completely drain the fuel from the device and properly attach the tank cap once the procedure of draining has been completed.
- Remove the spark plug (**Fig. 18, V**) and insert some oil into the cylinder.
- Pull the rope start a few times after applying oil and rotate the crankshaft to distribute the oil.
- Reinsert the spark plug (**Fig. 18, V**).
- To protect the device from dust and other forms of pollution, wrap it into a plastic bag or foil.
- Store the ground drill within a dry environment inaccessible to children. Make thereby sure that it is stored with sufficient distance to the ground and potential heat sources.

Troubleshooting

Ignition problems

Problem		Possible cause	Solution
Ignition (no ignition spark)	Spark plug	Spark plug is polluted / wet	Clean and dry.
		Dirt accumulation on the spark plug	Clean.
		Distance between electrodes is too small / large	Set distance to 0.6–0.7 mm
		Electrode burnt out	Replace the spark plug.
	Magneto	Insulation is damaged	Replace the spark plug.
		Cable is broken / damaged	Replace.
		Insulation of the coil is damaged	Replace.
Spark plug functions	Compression and fuel supply work	Distance between stator and rotor is too large	Set distance to 0.4 mm.
		Too much fuel	Drain some fuel.
	Working fuel supply, but insufficient compression	Two-stroke mixture is old / polluted / watery	Drain completely and replace.
		Cylinder and piston ring are worn	Replace worn out parts.
	Carburettor is not supplied with fuel	Fuel tank is empty	Refuel.
		Fuel supply is closed	Open the supply.
		Fuel valve is clogged	Clean the valve.

Loss of performance

Problem	Possible cause	Solution
Functional compression with ignition spark	Fuel tank draws air	Properly close the fuel cap.
	Carburettor hose draws air	Fasten or replace the gasket.
	Fuel is watery	Replace the fuel.
	Filter plate is clogged	Clean the filter plate.
	Exhaust pipe / cylinder is polluted	Clean.



Motor overheats	Fuel is too thin	Set the carburettor.
	Cylinder is polluted	Clean the cylinder.
Motor is very noisy or stutters	False petrol oil mixing ratio	Drain fuel and replace.
	Combustion chamber is polluted	Clean combustion chamber.
	Moving parts are worn	Check and replace worn parts.

Motor shuts down while operating

Problem	Possible cause	Solution
Motor suddenly stops operating	Piston is blocked / torn	Repair or replace the piston.
	Short circuit due to polluted spark plug	Clean the spark plug.
	Magneto is defect	Have the magneto be repaired or replaced.
The motor slowly turns off	Not enough fuel	Refuel.
	Carburettor is polluted	Clean the carburettor.
	Fuel is watery	Drain and replace the fuel.

Other problems

Problem	Possible cause	Solution
Motor operates, but auger does not rotate	Coupling is damaged	Replace the coupling.
	Auger does not properly fit the gearbox	Replace with a fitting auger.
Gearbox emits unusual noises	Gearbox is worn	Replace the worn parts.
	Insufficient lubrication	Clean and grease the device.
	Pollution inside the gearbox	Clean and grease the gearbox.

Important! Maintenance work not listed in this manual should only be carried out by qualified personnel. Only original parts of the same quality should be used for repairs. No responsibility is assumed for damage caused by improper maintenance or use.

Important notice:

The reprint or reproduction, even of excerpts, and any commercial use, even in part, of this instruction manual require the written permission of WilTec Wildanger Technik GmbH.