

User's Manual

Hydraulic Pipe Bender

62912



Illustration similar, may vary depending on model

Read and follow the operating instructions and safety information before using for the first time.

Technical changes reserved!

Illustrations, functional steps, and technical data may deviate insignificantly due to continuous further developments.

Updating the documentation

If you have suggestions for improvement or have found any irregularities, please contact us.



The information contained in this document may alter at any time without prior notice. No part of this document may be copied or otherwise duplicated without prior written consent. All rights reserved. WilTec Wildanger Technik GmbH cannot be held liable for any possible mistakes in this operating manual, nor in the diagrams and illustrations shown.

Although WilTec Wildanger Technik GmbH has made every possible effort to ensure that this operating manual is complete, accurate, and up-to-date, errors cannot be ruled out entirely.

If you have found an error or wish to suggest an improvement, we look forward to hearing from you. Send us an e-mail to:

service@wiltec.info

or use our contact form:

<https://www.wiltec.de/contacts/>

The most recent version of this manual in several languages can be found in our online shop:

<https://www.wiltec.de/docsearch>

Our postal address is:

WilTec Wildanger Technik GmbH
Königsbenden 12
52249 Eschweiler – Germany

To return your goods for exchange, repair, or other purposes, please use the following address. Attention! To allow for a trouble-free complaint or return, it is important to contact our customer service team before returning your goods.

Retourenabteilung
WilTec Wildanger Technik GmbH
Königsbenden 28
52249 Eschweiler – Germany

E-mail: **service@wiltec.info**

Tel: +49 2403 55592-0

Fax: +49 2403 55592-15



Introduction

Thank you for choosing to purchase this quality product. To minimise the risk of injury, we ask you to always take some basic safety precautions when using this product. Please read this operating manual carefully and make sure that you understand it.

Keep these operation instructions in a safe place.

Safety instructions

- Keep your working area tidy. Untidy work areas invite accidents.
- Consider the conditions of your working area. Do not work in damp, wet, or badly lit areas. Do not expose the device to rain. Always keep your working area well illuminated.
- Keep children away. Children must not be near the work area. Do not allow children to operate the device.
- Store non-used devices. If not using the device, keep it in a dry place. If possible, keep it out of children's reach.
- Never apply force on tools or machines. They will operate more reliably and with more safety if used for applications that they have been designed for.
- Use the appropriate tool. Do not use small tools or accessories for work that would need to be done with a large industrial machine. Never use tools or devices for work that they have not been designed for.
- Wear appropriate clothing. Do not wear loose clothing or jewellery that could get caught in moving parts. It is advisable to wear protective work gloves and anti-slip shoes. Tie long hair together to avoid it getting caught by the machine.
- Wear a suitable protective equipment (protective goggles, protective gloves, etc.).
- Do not stoop down too far. Ensure a safe stand and keep your balance.
- Always maintain tools with care. Keep tools proper to ensure their functioning reliably and safely. Obey the instructions on lubricating and replacing accessory parts. Always keep the handles clean, dry, and free from oil and grease.
- Stay alert. Concentrate on what you are doing and work with common sense. Do not use the device when being tired or under the influence of alcohol, drugs, or medicine. Read the warnings that are on and in the packaging of your medicine to know if your perception or reflexes are impaired by the medicine that you take. In case you are not sure, you should not operate tools or devices.
- Before operating any tool or device, check it for missing or damaged components. Any part that could be damaged must be checked properly for its operability. Check the alignment of moving parts and ensure that they are not blocked or otherwise damaged. Ensure that no part is damaged or otherwise limited in operability. Any damage should be repaired or replaced by a specialist.
- When repairing the device, only use identical spare parts. Only use accessories designed for use with this device.
- Always stay behind the device to avoid accidents.

Main components and their name

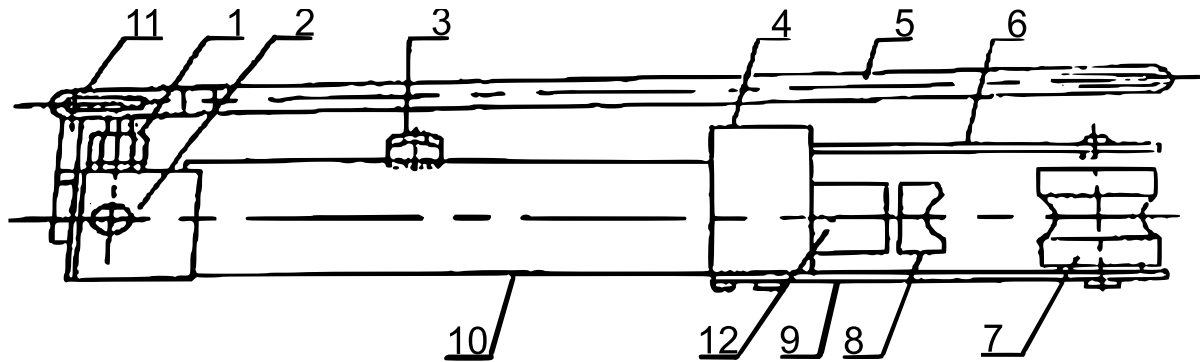

No	Name
1	Piston pump
2	Relief valve
3	Valve screw
4	Fixing block
5	Handle
6	Upper board
7	Return spring
8	Bending insert
9	Lower board
10	Guide sleeve
11	Handle holder
12	Cylinder

Operation

1. First, untighten the oil clutch screw to allow the air to circulate freely inside the tank. It is advisable to apply lubricating oil onto the surface of the form and pipe.
2. Depending on the size of the pipe that shall be bent, select the appropriate bending form, adjust the position of the support wheel, and attach the pipe onto the form. (The pipe diameter should approximately correspond to the width of the groove of the form. The thickness of the wall of the pipe should not be too thin, as the bending would be warped and the form damaged.)
3. Then tighten the relief valve on the right-hand side of the machine and press the handle to bend the pipe.
4. After the bending is finished, untighten the relief valve. The cylinder is retracted automatically. Open the upper panel to separate the pipe from the form and to remove it.

Cleaning and maintenance

- Regularly clean the device.
- When filling the oil tank, the oil must be filtered. If possible, use a special filter.
- The filtering device should be cleaned regularly.
- The hydraulic oil used for this device is of type HLP 15.

Important Note: Reproduction and any commercial use (of parts) of this operating manual, requires a written permission of WilTec Wildanger Technik GmbH.