

# User's manual

## Welding Machine Flux/MIG/MMA 30–220 A 63321



Illustration similar, may vary depending on model

Read and follow the operating instructions and safety information before using for the first time.

Technical changes reserved!

Illustrations, functional steps, and technical data may deviate insignificantly due to continuous further developments.

Updating the documentation

If you have suggestions for improvement or have found any irregularities, please contact us.



The information contained in this document may alter at any time without prior notice. No part of this document may be copied or otherwise duplicated without prior written consent. All rights reserved. WilTec Wildanger Technik GmbH cannot be held liable for any possible mistakes in this operating manual, nor in the diagrams and illustrations shown.

Although WilTec Wildanger Technik GmbH has made every possible effort to ensure that this operating manual is complete, accurate, and up-to-date, errors cannot be ruled out entirely.

If you have found an error or wish to suggest an improvement, we look forward to hearing from you. Send us an e-mail to:

[service@wiltec.info](mailto:service@wiltec.info)

or use our contact form:

<https://www.wiltec.de/contacts/>

The most recent version of this manual in several languages can be found in our online shop:

<https://www.wiltec.de/docsearch>

Our postal address is:

WilTec Wildanger Technik GmbH  
Königsbenden 12  
52249 Eschweiler – Germany

To return your goods for exchange, repair, or other purposes, please use the following address. Attention! To allow for a trouble-free complaint or return, it is important to contact our customer service team before returning your goods.

Retourenabteilung  
WilTec Wildanger Technik GmbH  
Königsbenden 28  
52249 Eschweiler – Germany

E-mail: **service@wiltec.info**  
Tel: +49 2403 55592-0  
Fax: +49 2403 55592-15



## Introduction

Thank you for choosing to purchase this quality product. To minimise the risk of injury, we ask you to always take some basic safety precautions when using this product. Please read this operating manual carefully and make sure that you understand it.

Keep these operation instructions in a safe place.

## Product properties

- This welder, a handy and powerful lightweight, has a strap with the help of which it is easy to carry it. The device is suitable for a wide range of different applications and can be operated easily at different spots when using a long extension cable. On construction sites, it is even operable with a current generator.
- The welding voltage and welding wire speed are adjusted on one control depending on how thick the welding sheet is. Thereby, it is especially easy to make the correct adjustments.
- The machine reaches its best performance with 0.8 mm diameter welding wires. However, 0.6 mm, 0.9 mm, or 1.0 mm diameter solid wires can also be used for welding.

## On welding

- The welding results not only depend on the individual welding machine, but also on the workpiece and work environment. That is why the user absolutely should obey the instructions of this manual.
- During welding, electric current is led to the welding wire and workpiece via the welding nozzle. A mass cable attached to the workpiece leads the current back to the device, thus creating a closed circuit. The current flows freely when the mass clamp is correctly attached to the workpiece and the contact surface of the workpiece is clean and free of paint and rust.
- For welding, the user must apply shielding gas to prevent air from mixing with the weld pool. Carbon dioxide or a mixture of carbon dioxide and argon is suitable for use as shielding gas. Some welding wires form shielding gas themselves that is generated during melting of the wire filling; in that case, additional shielding gas is not required.

## Intended use

- This device may only be used according to the intended use. Each use exceeding the intended use is forbidden!
- The user is responsible for damages or injuries of all kind caused by incorrect use.
- You may only use welding electrodes suitable for use with the device.
- Compliance with the safety, assembly, and operation instructions of this manual is also part of the intended use.
- Persons using and maintaining the device must be familiarised with it and be informed about all possible dangers. Furthermore, the applicable accident prevention regulations are strictly to be followed.
- You must also obey general instructions on occupational health and safety engineering.
- If the device is modified in any way, the manufacturer is no longer to be held responsible for damages caused by these modifications.
- The device is not designed for commercial, artisanal, or industrial use, but for private hobby/DIY use only. All further use is explicitly forbidden and is not considered as intended use.



## Safety instructions

<b>Read manual!</b>	<b>Use welding mask!</b>	<b>Use mask!</b>	<b>Wear protection clothes!</b>
<b>Wear hand protection!</b>	<b>Wear ear protection!</b>	<b>Wear foot protection!</b>	

**⚠ Attention!** Should you hand the device over to a third party, do also hand over the manual/safety instructions. We are not to be held responsible for any accidents or damages caused by non-compliance with this manual or the safety instructions.

**⚠ Attention!** For your own safety, operate the welding machine **AFTER** reading the safety instructions.

**⚠ Attention!** **ONLY** use the device according to the intended use defined in this manual. The welding machine must **NOT** be used

- in rooms without sufficient ventilation,
- in damp or wet zones,
- in explosive zones,
- for defrosting pipes,
- near persons with pacemakers,
- near easily inflammable material.

Incorrect use of this machine might be dangerous for persons, animals, and objects. The user of this device is responsible for his or her own safety and the safety of other persons. Thus, do read this manual and obey the regulations precisely.

## Safety instructions

### *General safety and accident prevention regulations*

- In addition to the instructions in this manual, you must obey the **legal general safety and accident prevention regulations**.
- **Hand over this manual to third parties.** Make sure that third parties only use this product after receiving the necessary instructions.
- The device is **not** intended for use by persons (including children) with impaired or limited physical, sensory, and mental abilities, or lack of experience and/or real knowledge, unless they are supervised by a person responsible for their safety or follow the instructions made by this person on how to correctly use the device. Children should be supervised to ensure that they do not play with the device. Children must not use this device.
- **Always pay attention and concentrate on what you are doing.** Do not perform work with this product when being unalert or influenced by alcohol, drugs, or medicine. Even a short moment of inattention during the use of this device might cause severe accidents and injuries.



### *Safety instructions concerning the use of the welding machine*

- **Make for a secure stand.** Make sure to mount the device on a stable and safe surface.
- **Avoid contact with hot parts.** Do not touch any hot parts of this device. Keep in mind that various components, storing heat, might cause burns even after the use of this device.
- **See for any damages.** Before using the device, check it for possible damages. Should the device be damaged, it must not be put into operation.
- **Do not use sharp objects.** Never introduce sharp and/or metallic objects in the inside of the device.
- **Do not misuse.** Only use the device according to the intended use defined in this manual.
- **Perform regular checks.** The use of this device can cause wear and tear of certain parts. Therefore, regularly check the device for possible damages and faults.
- **Correct use of the power cable.** Never pull out the plug by pulling on the power cable and protect all cables from oil, sharp edges, and high temperatures. During work, make sure not to touch the cables with hot objects. The power cable must not be damaged. If the connection line is damaged, it must be replaced with a new one.
- **During operation, the device should not be confined or placed directly at a wall** so that enough air is always let in through the louvres.
- **Arc welding causes sparks, melting of metal parts, and smoke.** Therefore, make sure to remove all inflammable substances and/or material from the working zone.
- **Do not weld on containers, receptacles, or pipes that have contained inflammable liquids or gases.**
- **Avoid any direct contact with the welding circuit;** no-load voltage forming between the electrode holder and earth terminal can be dangerous.
- **Do not store or use the device in damp or wet zones or in the rain.**



#### **Attention!**

- Welding arc radiation can cause eye damages and skin burns.
- Sparks and drops of melted metal form during arc welding. The welded piece begins to glow and stays hot during quite a long time.
- Vapours that might be harmful form during arc welding.
- Every electric shock might be deadly.
- Define safety distances for the welding zone and make sure that unauthorised persons and/or persons not wearing protective clothing cannot enter the work zone. Danger by flying sparks!
- Protect yourself and bystanders from all possible dangers caused by arc welding.

### *Hazard sources during arc welding*

**Many hazards are caused by arc welding. Therefore, it is very important that the welder obeys the following regulations for not to endanger himself or herself or other persons and to avoid damages to the device and persons.**

- **Should contact voltages form,** immediately switch off the device and have it checked by a qualified person.
- **Make sure that all electric contacts on the welding-current side are always in good condition.**
- **During welding, always wear insulating gloves on both hands.** They will protect you from electric shocks (e.g., cause by no-load voltage of the welding circuit), harmful radiation (warmth and ultraviolet rays), glowing metal, and slag splashes.
- **Wear solid insulating footwear;** the shoes should keep their insulating feature in wet conditions. Mid-height footwear is not suitable, for glowing metal drop falling can cause burns.
- **Wear suitable clothing,** no synthetical clothing.
- **Do not look into the welding arc without eye protection;** only use a welding helmet with protective glass according to DIN. Besides light and heat radiation causing glares and burns, the welding arc also emits ultraviolet rays. If the protection is inadequate, these invisible ultraviolet rays cause very painful conjunctivitis (pinkeye) that only becomes noticeable a few hours later. Moreover, UV radiation has an effect on unprotected skins as would have sunburn.



- **Persons or assistant near the welding arc must be informed about the dangers and be equipped with the necessary protection means;** if necessary, mount protective panels.
- **No welding works may be performed on containers where gases, fuels, mineral oils, etc. are stored or have been stored, even in case they have been emptied a long time ago; residues might cause explosions.**
- **There are special regulations for welding work to be performed in rooms with an inflammable or explosive ambience.**

#### *Risk of accident caused by electric shock*

**With no welding arc burning, there is a no-load voltage  $U_0$  between the earth terminal and electrode holder. This voltage can be dangerous to life if the welder touches the metal clamping jaws of the electrode holder and the piece with unprotected hands.**

#### *Narrow and hot rooms*

- **Performing work in narrow or hot rooms** is a special risk situation that necessitates additional, special protective clothing to be worn. Insulating pads (e.g., rubber mats, wood grates, etc.) must possibly be used.
- **Risk of accidents caused by deficiency of air in narrow rooms. Considerable quantities of vapour and gas form during welding.** Make sure that vapours and gases can escape through suitable vents. However, do not take in oxygen. This would increase the risk of fire.

#### *Protective clothing*

During work, the welder's entire body must be protected from radiation and burns by wearing clothing and facial protection.

#### *Fire hazard due to flying sparks*

If melted or glowing metal and slag drops fall on inflammable material, this might inflame and cause a fire. Therefore, remove any inflammable objects from the work zone before beginning to weld.

#### *Explosion hazard*

Both welding sparks and the high-heated welding spot might cause explosions. Therefore, do not use the device inside explosive zones with inflammable liquids, gases, and paint mists present.

#### **Furthermore, note the following:**

- Immediately remove the electrode from its holder after finishing welding work to avoid a welding arc from accidentally forming.
- During operation of the device, do not put the electrode holder on the welding machine or on any other electric device.
- Before finishing work, do not touch the electrode or another metal objects in contact with the electrode.
- Immediately disconnect the power supply after finishing welding work.
- Make sure that no cable wraps around your body.
- **Make sure that you do not stand between the earth terminal and electrode holder during welding. The electrode holder and earth terminal must always be on the same side.**

#### *Handling shielding gas bottles*

- **Bad handling of shielding gas bottles!** Badly handling shielding gas bottles may lead to severe injuries or even death.
- Obey all instructions given by the manufacturer of the gas and the decree on pressure gas!
- Place the shielding gas bottle in the spot previewed and secure it with fixing elements!
- Avoid any heating up of the shielding gas bottle!

## Residual risks

Despite obeying to the intended use, residual risks cannot be fully excluded. Due to the type and design of the device, the following risks can result:

- a) eye injuries by glazing,
- b) injuries caused by burns after touching hot parts of the device or piece,
- c) risks of accident and fire caused by flying sparks or slag particles when not being sufficiently protected,
- d) harmful emission of vapour and gases with deficiency of air or insufficient extraction inside closed rooms.

## Using the welder

On reception, this welder is ready to use and already has a 0.8 mm welding wire installed. When using a non-recommended welding wire, make sure that the size and type of that is suitable for the contact tip of the welding gun, wire-feed control, and polarity of the device.

### Before use

- The device is placed in a robust packaging especially designed for it. However, on reception, check it for possible transport damages. Also check if the device is the article ordered and if all required instructions are included. Recycle the packaging material.
- The device must be transported in an upright position.
- **Attention!** Always lift the device on its handle, never on the welding gun or a cable.
- The device is suitable for both indoor and outdoor use; nevertheless, it should be protected from heavy rain and solar irradiation. Store it in a dry and clean place and protect it from sand and dust when using or storing it. It is advisable to use the device only in a temperature range from  $-20\text{ }^{\circ}\text{C}$  to  $+40\text{ }^{\circ}\text{C}$ .
- Place the device so that it does not touch any hot surface or comes into contact with sparks or weld spatters.
- Make sure that the air flow through the device is free.

## Control elements and description

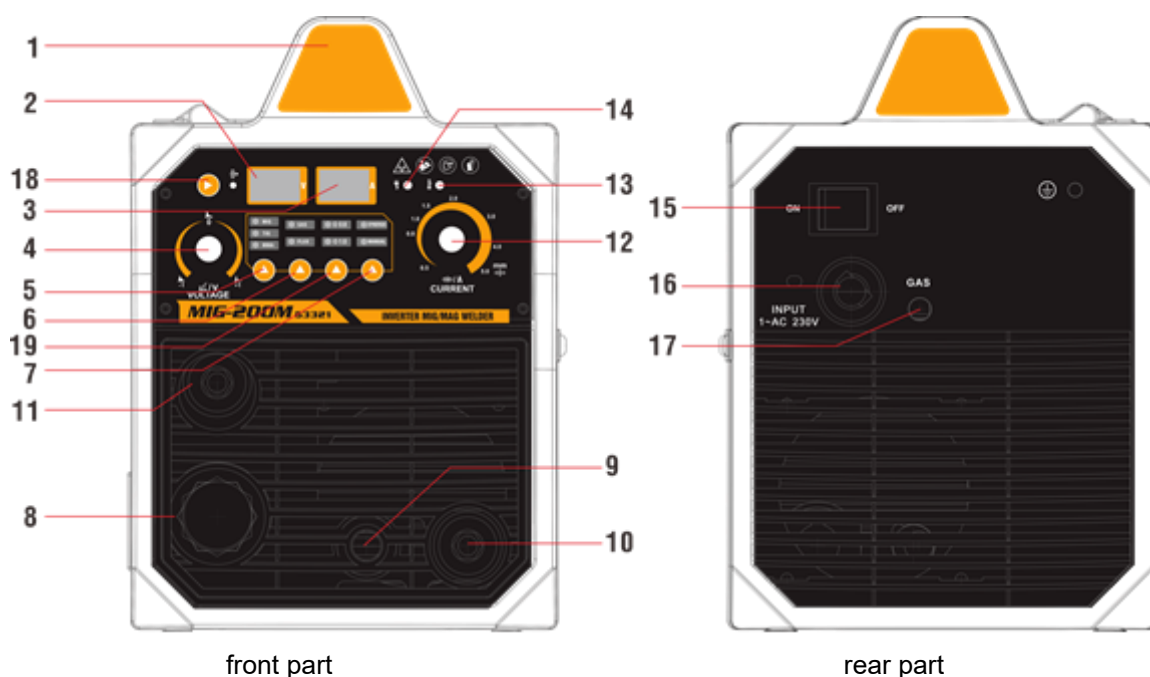





No	Name
1	Handle
2	Welding current display
3	Welding voltage display
4	Welding voltage regulator
5	MIG/MMA mode switch
6	GAS/FLUX (welding wire) mode switch
7	SYNERGIC/MANUAL mode switch
8	Connection to MIG welding gun
9	Polarity toggle cable
10	Negative output connection (-)
11	Positive output connection (+)
12	Welding current/wire feed speed regulator
13	Warning LED
14	Power input display
15	Main switch On/Off
16	Connection point to power cable
17	Connection to gas
18	Quick wire feed
19	0.8 mm and 1.0 mm wire selection

### Connection for Gas and FLUX (welding wire) application

#### *Using gas (when using welding wire)*

Polarity toggle cable (+), earth clamp (-), connect welding gun to “” and fix.

#### *Not using gas (when using filler wire)*

Polarity toggle cable (-), earth clamp (+), connect welding gun to “” and fix.

#### *Cable and hose connections*

- Power supply:
  - The device is equipped with a long power cord with plug. Plug the plug into the power socket.
  - **Note!** The energy supply must be protection with a 16 A slow-blow fuse.
  - If using an extension cord, be sure that the diameter of that equals at least the diameter of the cable of tension entry (3×2.5 mm<sup>2</sup>). The extension cable may only be 50 m of length.
  - The welder can also be operated via a current generator. The minimum power of this generator must be 5.5 kVA; however, we recommend use of an 8.0 kVA generator, that allows the welder to develop its entire performance.
- Mass:
  - The mass cable is already connected to the device. Clean the workpiece surface and attach the mass clamp to it to create a trouble-free closed circuit required for welding.



- Welding gun:
  - The welding gun is already connected to the device. It leads the welding wire, shielding gas, and current to the welding spot. By pressing the trigger of the welding gun, shielding gas is set free and wire-feed begins to operate. The arc ignites when the welding wire touches the workpiece.
  - The neck of the welding gun can be rotated by 360°. Make sure that, when turning the neck of the welding gun, this must point nearly entirely downwards. This will prevent it from being damaged or overheating.
  - **Note!** Before using a welding wire with a diameter other than 0.8 mm, the contact tip of the welding gun must be exchanged to fit the thickness of the wire.
  
- Shielding gas:
  - Carbon dioxide or a mixture of argon and carbon dioxide is suitable for use as shielding gas, that must displace the air around the arc. The thickness of the welding piece and the welding power define the amount of shielding gas needing to escape.
  - Connect the bayonet coupling of the shielding gas hose with the hose connection of the device; the other end of the shielding gas hose is connected to the regulating valve of the gas cylinder.

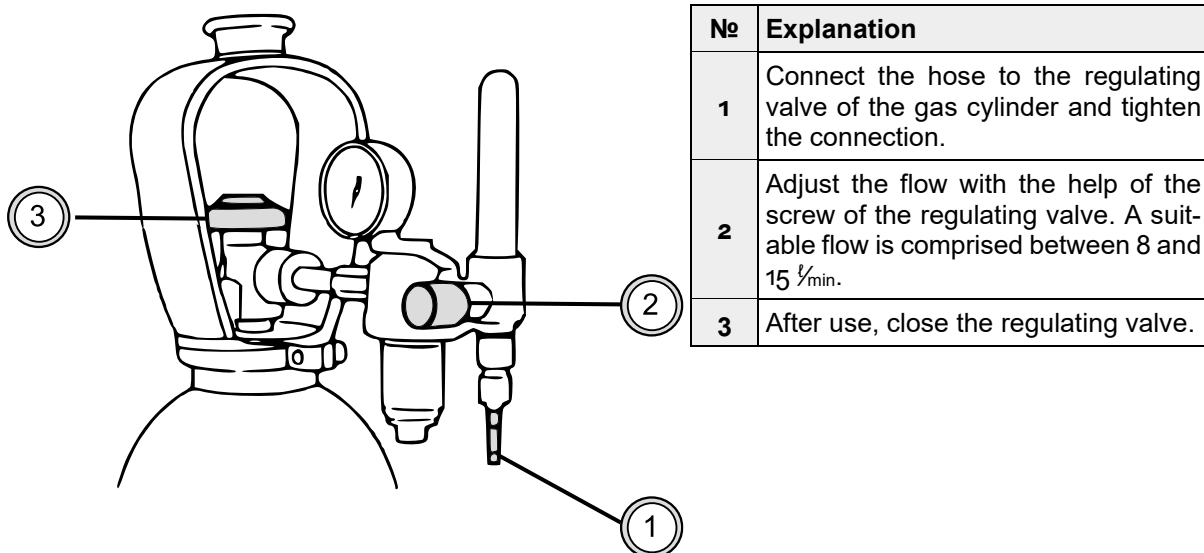

**Note!** Only use shielding gases suitable for the material that you will weld on. The gas cylinder must remain in an upright position and does not must be able to tilt. Then, connect the regulating valve.

### Solid wire

The device comes along with the welding gun connected to the positive pole; thus, it is suitable for welding solid steel wires without further adjustments.

#### *Adapting the guide notch of the wire-feed control*

Ex-factory, the wire-feed control guide notch is adjusted to match 0.6 to 0.8 mm welding wires. If wanting to use a 1 mm welding wire, you need to adapt the guide notch.

1. Open the wire-feed control on the pressure control lever.
2. Switch the device on on the main switch.
3. Press the trigger of the welding gun to bring the feed roll to a position where the fixing screw points upwards and can be unscrewed.
4. Switch the device off on the main switch.
5. Turn half-way the fixing screw of the feed roll with a 2.0 mm socket head wrench.
6. Remove the feed roll from its shaft.

7. Turn the feed roll and replace it on the shaft all the way down. Make sure that the screw point upwards.
8. Retighten the fixing screw of the feed roll.

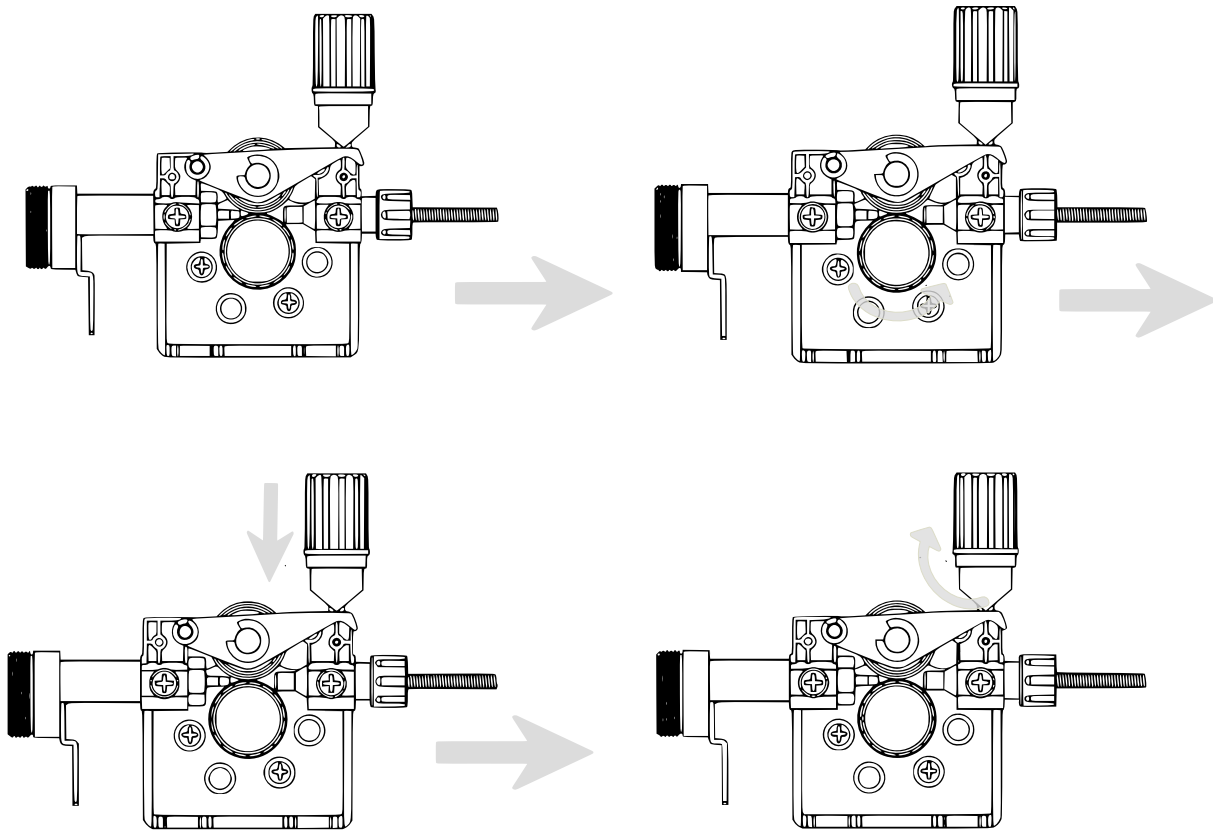

Example – may vary depending on model

### Threading the solid wire

1. Open the coil housing by pressing the opening knob, then set in the wire coil so that it can turn anti-clockwise. This device accepts wire coils of 1 kg (100 mm diameter).
2. Fix the coil with the coil lock.
3. Detach the end of the wire from the coil, but hold it.
4. Pull approximately 20 cm of wire from the coil and straighten the portion of wire pulled out; cut the wire on the spot where it is straight.
5. Open the pressure control lever to open the wire-feed control drive.
6. Thread the wire through its rear feed and up to the wire feed of the welding gun.
7. Close the wire-feed control drive and lock it with the pressure control lever. Make sure that the wire runs inside the guide notch of the feed.
8. Via the pressure control lever, adjust the compression pressure, but be sure to not exceed the centre line of the scale. With too high a pressure, metal particles are worn off the surface of the wire, which might damage the wire. With too low a pressure, the drive gets out of place, causing the wire to run unevenly.
9. Press the trigger of the welding gun and wait for the wire to come out.
10. Close the cover of the coil housing.

**⚠ Attention!** Do not point the welding gun towards your own body or towards other persons while the wire is being inserted or coming out; never hold the hand in front of the contact tip; the cut-off end of the wire is extremely sharp! Neither hold your fingers near the feed rolls; they risk to be pinched between them.

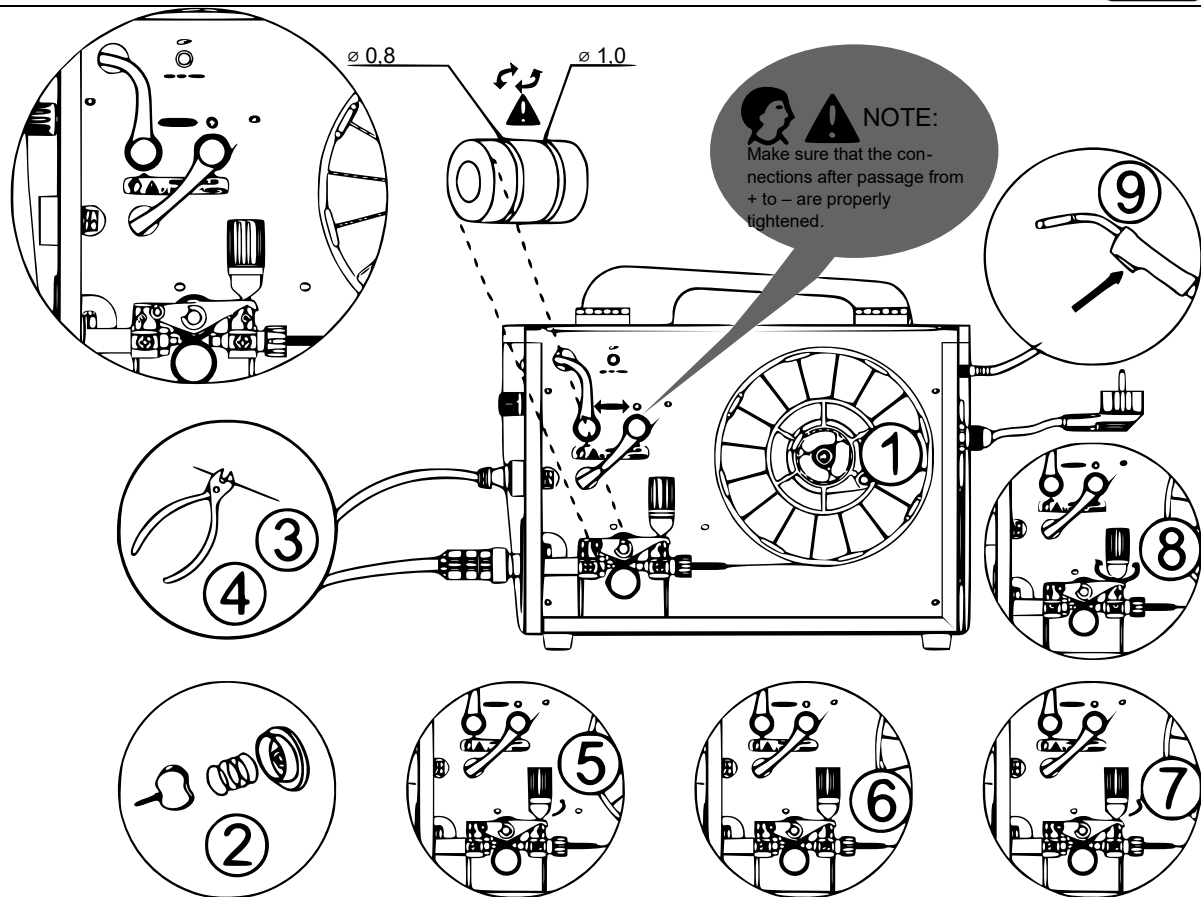

Example – may vary depending on model

### Reversing polarity

Certain solid wires are more suitable for being welded with the gun being attached to the negative pole; in that case, polarity should be reversed. Check the recommended polarity on the package of the solid wire!

1. Pull out the plug.
2. Bend the rubber cover of the mass cable to remove the cable.
3. Remove the nuts and washers holding the poles in place. Pay attention to the order of the washers!
4. Interchange the cables.
5. Re-attach the washers and re-tighten the nuts with a wrench.
6. Re-attach the rubber cover of the mass cable pole. This rubber cover must always protect the mass cable pole.

### Adjusting the welding power

- Adjusting the welding power depending on the thickness of the sheet to be welded on also affects the speed of the wire-feed control and the current led to the wire. Thereby, welding operations are possible in many different situations. But the type of connection and the root gap influence the amount of welding power, too.
- Via the welding power regulator, adjust a suitable value matching the thickness of the welding sheet that the fillets are to be welded on. Should you wish to work on sheets of different thicknesses, adjust a medium value.
- The sheet thickness scale is given in millimetres and calibrated on 0.8 mm wires. If using a 0.6 mm wire, adjust the welding power to a value slightly higher than the sheet thickness, if using a 0.9–1.0 mm wire, adjust the welding power to a value slightly lower.
- **Note!** When welding for the first time, it is advisable to adjust the arc length regulator to a medium value.

## Maintenance

When maintaining the device, you should also consider the frequency of use and environmental conditions. If used correctly and maintained regularly, the device will spare you unnecessary dysfunctions.

**Attention!** Pull out the plug before handling electric cables.

### Daily maintenance

- Remove weld spatters from the contact tip of the welding gun and check the individual parts. Immediately replace damaged components.
- Check the isolating tips of the welding gun neck for intactness and proper placing. Immediately replace damaged isolating components.
- Check the cable of the welding gun and the mass cable for tightness.
- Check the intake voltage cable and welding cable, replace damaged cables.

### Maintaining the wire feed

- Maintain the wire feed at least every time when you set in a different wire coil.
- Check the guide notch of the feed roll for wear and tear; replace the feed roll if necessary.
- Clean the wire feed of the welding gun with the help of compressed air.

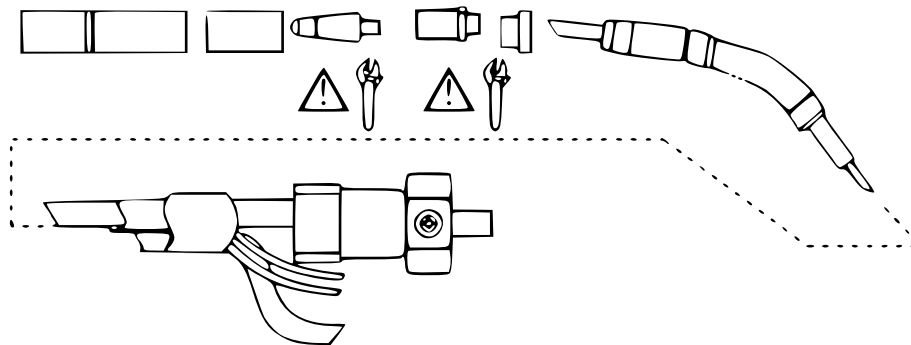

### Cleaning the wire feed

The pressure exerted on the welding wire by the feed roll causes metal dust to be worn off the surface of the wire; this dust then reaches the wire feed. If the wire feed is not cleaned, it is gradually clogged, causing dysfunctions of the feed. Clean the feed as follows:

1. Remove the welding gas nozzle, the contact tip, and the contact tip adaptor from the welding gun.
2. With a compressed air gun, blow compressed air onto the wire feed.
3. Also blow out the feed control and coil housing with compressed air.
4. Reattach the components of the welding gun. Tighten the contact tip and adaptor with a wrench.

### Replacing the wire feed

In case the wire feed is too worn or completely clogged, it needs to be replaced by a new one; proceed as follows:

1. Untighten the connection between the welding gun and device:
  - a) Untighten the connection of the cable clamp of the welding gun power cable by unscrewing the screws.
  - b) Remove the power cable of the welding gun from the connection pole on the device.
  - c) Remove the connector of the triggering conductor from the device.
  - d) Untighten the fixing screw of the welding gun.
  - e) Carefully remove the gun from the device. By doing so, all components will come out through the cable opening on the front.



2. Turn the fixing nut of the wire feed; thus, the end of the feed will be exposed.
3. Straighten the cable of the welding gun and pull out the wire feed from the gun.
4. Slide a new feed into the gun. Make sure that the wire feed also slides into the adaptor of the contact tip and that an O-ring is sitting on the device-sided end of the feed.
5. Re-tighten the fixing nut to lock the wire feed.
6. Cut off the wire feed at approximately 2 mm before the fixing nut and lime the sharp edges of the cut-off spot round.
7. Re-attach the welding gun to its previewed spot and re-tighten all components with a wrench.

### Technical specifications

<b>Entry voltage</b>	1~220 V ±10 % 1~230 V ±10 %
<b>Frequency (Hz)</b>	50/60
<b>Capacity (kVA)</b>	4.6
<b>Current (A)</b>	20–160
<b>Relative operating cycle (%)</b>	35
<b>Power factor</b>	0.7
<b>Efficiency (%)</b>	85
<b>Wire-feed control</b>	Internal
<b>Speed of wire-feed control (m/min)</b>	2.5–10
<b>Diameter of wire (mm)</b>	0.6–0.8
<b>Protection class</b>	IP21S

**Caution!**

<b>Diameter of electrode (mm)</b>	0.8–1
<b>Recommended metal plate thickness (mm)</b>	0.5–5
<b>Wire roll (kg)</b>	0.5–5

### Troubleshooting

Problem	Cause	Solution
Welding wire does not move or wire feed is getting entangled.	Damaged feed roll, feed, or contact tip	Check feed roll for excessive tightness or looseness.
		Check guide notch for wear and tear.
		Check wire feed for obstruction.
		Check if there are welding spatters on contact tip and if hole has become too narrow or too large due to wear and tear.
Operation diode is not lit.	No mains voltage	Check fuses.
		Check intake voltage cable and plug.
Bad welding result	Welding result is influenced by several factors.	Check adjustments of welding power regulator and arc length regulator.
		Check mass clamp for proper fixing, contact surface for cleanness, and cable and adaptors for intactness.
		Check shielding gas flow on welding gun tip.



		Check intake voltage for unevenness, excessive low or high level.
Overhitting diode is lit.	Device over-heated	Check cooling air for free flow.
		Wait for diode to go out after overheating.
		Check intake voltage for excessive low or high level.

## Regulations for waste disposal

The Waste Electrical and Electronic Equipment Directive (WEEE Directive, 2012/19/EU) of the EU was implemented in the German law related to electrical and electronic equipment and appliances.

All WilTec electric devices that fall under the WEEE directive are labelled with the symbol of a crossed-out wheeled rubbish bin. This symbol indicates that this electric device must not be disposed of with the domestic waste.

WilTec Technik GmbH is registered with the German registration authority EAR (Stiftung Elektro-Altgeräte Register) under the WEEE-registration number DE45283704.

Disposal of used electrical and electronic devices (intended for use in the countries of the European Union and other European countries with a separate waste collection system for these devices).

The symbol on the packaging or the product itself indicates that this product must not be treated as normal domestic waste but must be disposed of at a recycling collection station for electrical and electronic waste.

By disposing of this product correctly, you contribute to the protection of the environment and the health of your fellow people. Inappropriate disposal threatens the environment and health.



Material recycling helps to reduce the consumption of raw materials.

Additional information about the recycling of this product can be provided by your local commune, the municipal waste disposal facilities, or the store where you purchased the product.

Address:  
WilTec Wildanger Technik GmbH  
Königsbenden 12 / 28  
52249 Eschweiler Germany

### Important Note:

Reproduction and any commercial use (of parts) of this operating manual, requires a written permission of WilTec Wildanger Technik GmbH.