

User's Manual

2000 kg Axle Traverse 63855

wiltec



Illustration similar, may vary depending on model

Read and follow the operating instructions and safety information before using for the first time.

Technical changes reserved!

Illustrations, functional steps, and technical data may deviate insignificantly due to continuous further developments.

Updating the documentation

If you have suggestions for improvement or have found any irregularities, please contact us.



The information contained in this document may alter at any time without prior notice. No part of this document may be copied or otherwise duplicated without prior written consent. All rights reserved.

WilTec Wildanger Technik GmbH cannot be held liable for any possible mistakes in this operating manual, nor in the diagrams and illustrations shown.

Although WilTec Wildanger Technik GmbH has made every possible effort to ensure that this operating manual is complete, accurate, and up-to-date, errors cannot be ruled out entirely.

If you have found an error or wish to suggest an improvement, we look forward to hearing from you.

Send us an e-mail to:

service@wiltec.info

or use our contact form:

<https://www.wiltec.de/contacts/>

The most recent version of this manual in several languages can be found in our online shop:

<https://www.wiltec.de/docsearch>

Our postal address is:

WilTec Wildanger Technik GmbH
Königsbenden 12
52249 Eschweiler – Germany

To return your goods for exchange, repair, or other purposes, please use the following address. Attention! To allow for a trouble-free complaint or return, it is important to contact our customer service team before returning your goods.

Retourenabteilung
WilTec Wildanger Technik GmbH
Königsbenden 28
52249 Eschweiler – Germany

E-mail: **service@wiltec.info**

Tel: +49 2403 55592-0

Fax: +49 2403 55592-15



Introduction

Thank you for choosing to purchase this quality product. To minimise the risk of injury, we ask you to always take some basic safety precautions when using this product. Please read this operating manual carefully and make sure that you understand it. Keep these operation instructions in a safe place.

Safety instructions

- Do not exceed the maximum charge capacity of 2000 kg (4000 lbs).
- Make sure that the load is properly fixed to the device.
- Wear appropriate protective equipment (e.g., protective gloves, safety goggles).
- Do not use this traverse together with a car jack whose connecting bolt has not been safely fixed and entirely tightened.
- Do not modify the product in any way.
- Centre the load above the car jack saddle.
- Adjust the pads so that the traverse stays level during lifting.
- Only use with safety chains included. These must be properly fixed to avoid any overcharge.
- Only fix and use perpendicularly to car jack housing.
- Do not move a vehicle that sits on the traverse.
- Only use the traverse according to its intended usage.
- Do not use the traverse to lift a person.
- Keep clear from charges lifted.
- The traverse is not appropriate for aircraft use.
- Check the traverse before each use. Do not use it when parts are loose or damaged.
- The traverse is exclusively meant to serve as lifting device. Immediately after lifting, the vehicle must be supported and secured by appropriate means.

Assembly

Attention! Before assembling, read all safety instructions!

1. Remove the connecting screw of the saddle and the saddle itself from the car jack (not included).
2. Place the traverse onto the car jack.
3. With 3 t jacks with low profile and 3 t long-reach jacks, the spacer must not sit on the connecting screw. With other 3 t and 4 t car jack, slide the spacer onto the connecting screw.
4. Fix the connecting screw of the traverse and securely tighten it. When doing so, the traverse must be perpendicular to the housing of the car jack.



Use

1. Completely lower both saddle pads.
2. Align each saddle pad according to the lifting point of your vehicle, then centre the weight of the vehicle above the car jack.

Warning! Make sure that the traverse is at a right angle (90°) to the car jack.

3. Raise the traverse, using the car jack, until one of the saddle points is about to contact its corresponding lifting point of the vehicle.
4. Now raise the saddle pads until both pads contact the lifting points.
5. When lowering the car jack and traverse, stay clear.
6. Slowly lift the vehicle until it has reached the desired height.

Warning! When lifting, make sure that the traverse stays level and the load centred over the jack.

7. Place two jack stands at the recommended support points of your vehicle and adjust them so that they almost contact the support points.
8. When lowering the vehicle onto the stands, stay clear and lower the entire weight of the vehicle onto the stands before beginning to work under it.

Exploded view and parts list

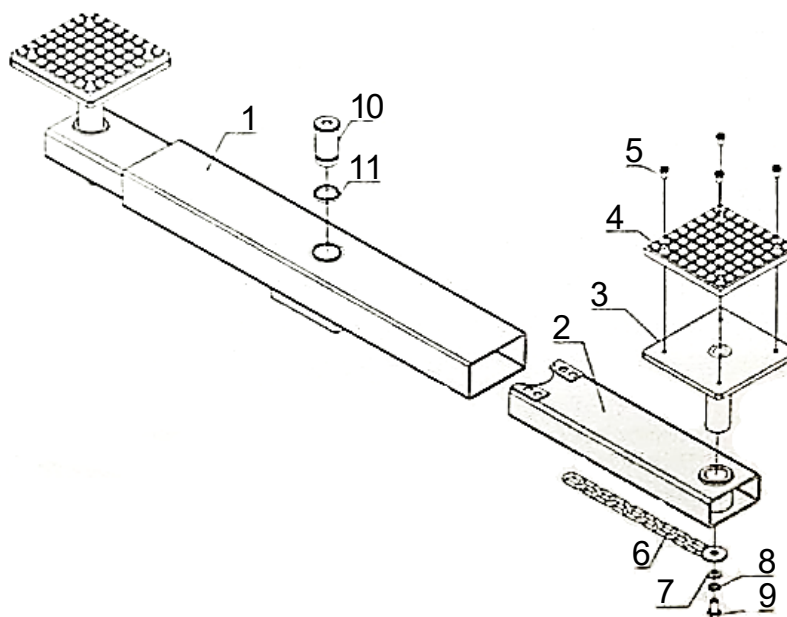

No	Name	Qty.	No	Name	Qty.
1	Holder	1	7	Washer	2
2	Extension tube	2	8	Washer	2
3	Saddle	2	9	Screw	2
4	Rubber pad	2	10	Connecting bolt	1
5	Screw	8	11	Spacer	1
6	Chain washer	2			

Important Note:

Reproduction and any commercial use (of parts) of this operating manual, requires a written permission of WilTec Wildanger Technik GmbH.