

Operation Manual

Drywall Panel Lift

64365

wiltec



Illustration similar, may vary depending on model

Read and follow the operating instructions and safety information before using for the first time.

Technical changes reserved!

Illustrations, functional steps, and technical data may deviate insignificantly due to continuous further developments.

Updating the documentation

If you have suggestions for improvement or have found any irregularities, please contact us.



The information contained in this document may alter at any time without prior notice. No part of this document may be copied or otherwise duplicated without prior written consent. All rights reserved. WilTec Wildanger Technik GmbH cannot be held liable for any possible mistakes in this operating manual, nor in the diagrams and illustrations shown.

Although WilTec Wildanger Technik GmbH has made every possible effort to ensure that this operating manual is complete, accurate, and up-to-date, errors cannot be ruled out entirely.

If you have found an error or wish to suggest an improvement, we look forward to hearing from you. Send us an e-mail to:

service@wiltec.info

or use our contact form:

<https://www.wiltec.de/contacts/>

The most recent version of this manual in several languages can be found in our online shop:

<https://www.wiltec.de/docsearch>

Our postal address is:

WilTec Wildanger Technik GmbH
Königsbenden 12
52249 Eschweiler Germany

To return your goods for exchange, repair, or other purposes, please use the following address. Attention! To allow for a trouble-free complaint or return, it is important to contact our customer service team before returning your goods.

Retourenabteilung
WilTec Wildanger Technik GmbH
Königsbenden 28
52249 Eschweiler Germany

E-mail: **service@wiltec.info**
Phone: +49 2403 55592-0
Fax: (+49 2403 55592-15)



Introduction

Thank you for choosing to purchase this quality product. To minimise the risk of injury, we ask you to always take some basic safety precautions when using this product. Please read this operating manual carefully and make sure that you understand it.

Keep these operation instructions in a safe place.

Proper use

- The drywall lift allows one person to lift a drywall panel that is up to 120×480 cm (4×16 ft) in size without assistance. The panel can be raised to a maximum height of 335 cm (11 ft) for attachment to level ceilings-or (with the cradle of the lift tilted) to sloped ceilings or side walls.
- The cradle of the lift lowers to 85 cm (34 in) off the floor for easy panel loading, and can support up to 70 kg (150 lbs).
- This manual explains the assembly, use, and disassembly of the dry wall lift after use for safe transport and simple storage. We strongly recommend our clients to obey the instructions and information for use before using the drywall lift.

Important instructions:



CAUTION!

To protect yourself against serious injury, use common sense and observe the following precautions when operating the dry-wall lift.

ALWAYS:

- read the instructions before use and make sure to respect all warnings.
- check the lift before daily use, especially the cable.
- assimilate the lift to the room temperature before beginning to work (movement from a cold to a warm room may cause condensations that can impair the effect of the brake).
- make sure that the brake drum is clean and dry before using the lift.
- keep the work area free of obstacles.
- wear a hard hat when working with the lift.
- pay attention for hanging obstacles when lifting a panel.

NEVER:

- use the lift in case the traverse fixation is not secured with its fastening springs.
- use the lift for any objects but drywall panels.
- lift more than one panel at the same time.
- lift more than 70 kg (150 lbs).

Assembly

Main components

The drywall lift is shipped as several components that must be assembled before use:

- tripod base assembly
- frame assembly, including a winch assembly and standard (120 cm or 4-ft) telescoping lift sections
- cradle assembly, without its detachable crossarms
- two cradle crossarm assemblies

⚠ **ATTENTION**

- Always wear a hard hat and protective goggles.
- Max. lifting charge: 68 kg
- Never exceed the max. lifting charge.
- A damaged, worn, or improperly mounted cable may cause severe injuries or damages. Check cable before each use. Immediately replace a damaged cable.
- Only one drywall panel can be lifted onto the lift at once.
- Store all components of the drywall lift in a dry environment.
- Thoroughly read the instructions for use before operating the drywall panel lift.

Assembly instructions

1. Setting up the tripod base
 - a. Set the base on the floor, resting on its casters.
 - b. Press down on the slide yoke ring **(1)**, hold the ring down while you swing the two forward legs out until the yoke ring snaps into the locking hole on the bottom of the slide tube (Fig. 1).
 - c. To prevent the tripod base from rolling backward during assembly, lower the backstop **(2)** as shown.
2. Set the frame assembly onto the two “V” angles on the tripod base. Lower the frame about 2–3 cm (1 in) until it is secured by the angles. Before continuing, be sure that the frame is pushed all the way down and held securely by the angles.

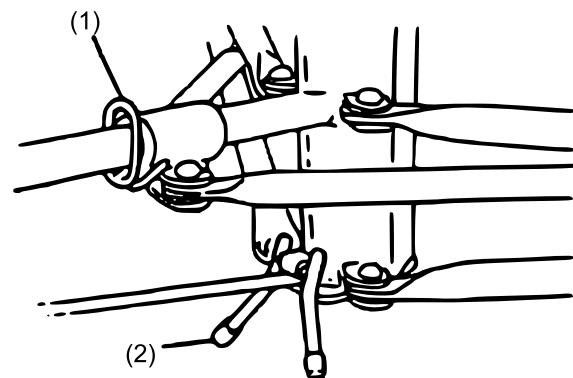
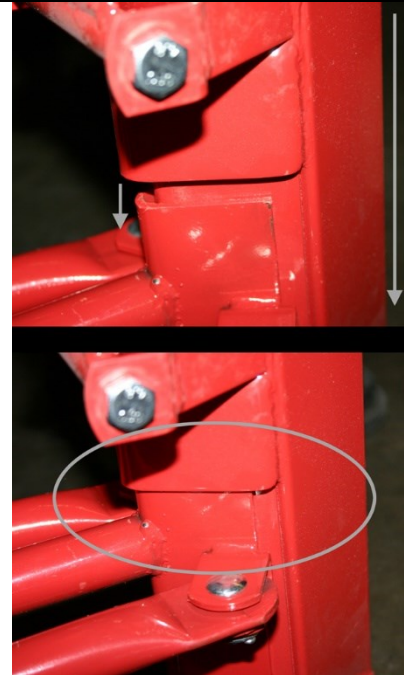
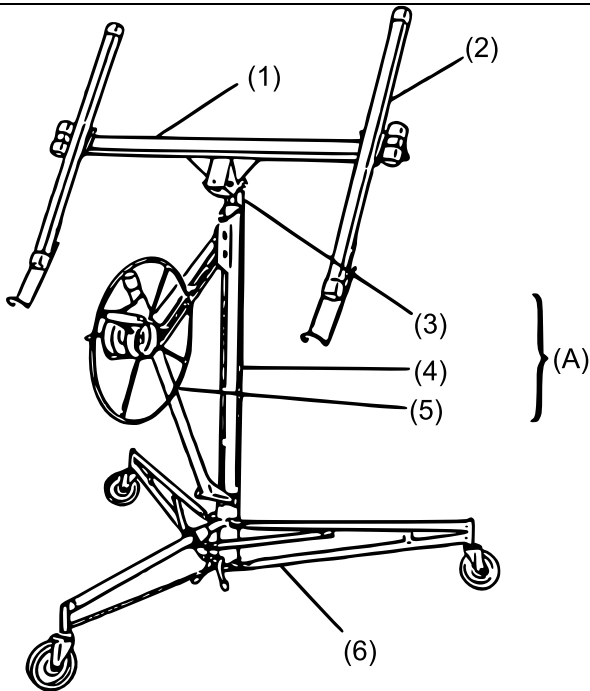
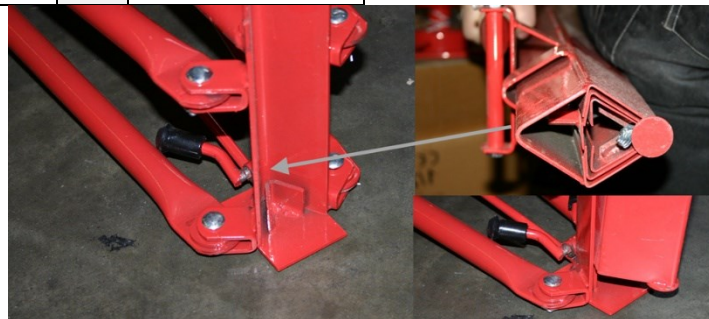

Figure 1



Components of drywall lift

No	Name	No	Name
1	Cradle	5	Winch
2	Crossarm	6	Tripod base
3	Telescoping sections	A	Frame assembly
4	Housing		



3. Attach the handle to the winch wheel. Tighten the nut, then back it off slightly so the handle turns freely.
4. Move the winch assembly into its working position:
 - a. Hold the winch wheel and brake arm as shown in Fig. 2 (1). Rotate the winch wheel forward slightly (2) while you lift on the brake arm to release the brake.
 - b. Raise the brake arm all the way up. Grasp the winch post, and grip the brake arm firmly with your thumb (1) (Fig. 3).

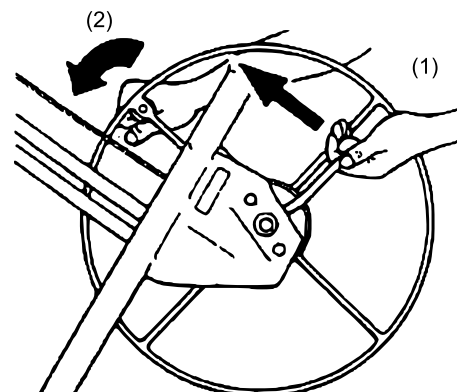

Figure 2

- c. Place your right hand on top of the frame. Continue to grip the brake arm (1) as needed to prevent cable backlash. Pull the winch assembly all the way towards you (Fig. 4).
 - d. When the winch is fully extended (away from the frame housing), release the brake arm and swing the retaining hook (2) away so it no longer secures the telescoping sections inside the frame housing (Fig. 4).
5. Press the winch assembly slightly back toward the frame. This automatically engages the slide bar lock to keep the winch fully extended (Fig. 5).

IMPORTANT: Before continuing, be sure that the slide bar lock (1) is fully engaged — that is, rotated clockwise as far as possible (2).

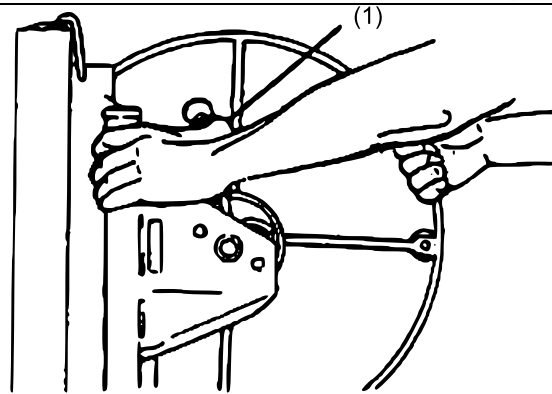

Figure 3

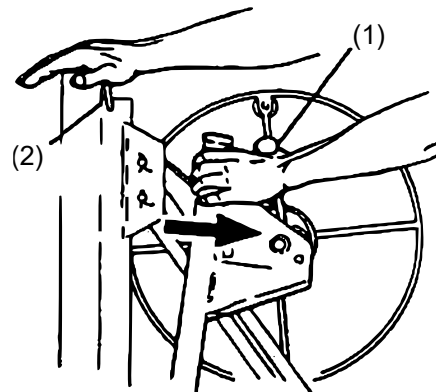

Figure 4

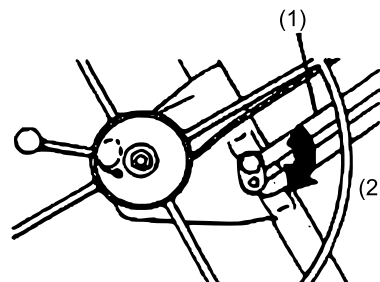

Figure 5



ATTENTION!

To avoid injury, slide bar lock must be fully engaged if winch assembly is extended.

6. Attach the cradle to the frame (Fig. 6):
- a. Insert the post of the cradle into the opening on top of the frame.
 - b. Secure the cradle to the frame by snapping the tilt latch upward so it hooks over the stud (2) on the cradle (1).
7. Attach the crossarms to the cradle:
- Note:** The crossarms are interchangeable.
- a. Slide the tapered plates on the crossarms into the tapered sockets on the cradle (Fig. 7).
 - b. Press each crossarm forward into the socket until the spring tab (1)

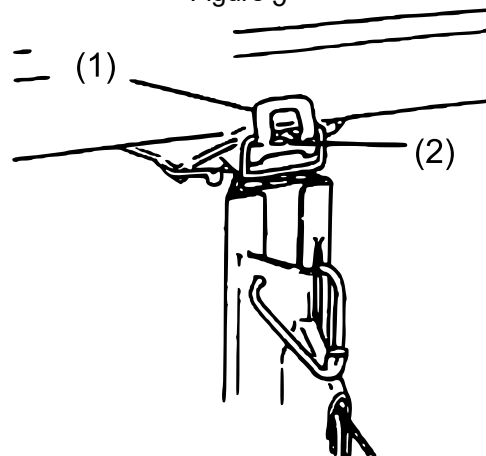

Figure 6

on the bottom of the crossarm snaps into place (Fig. 8).

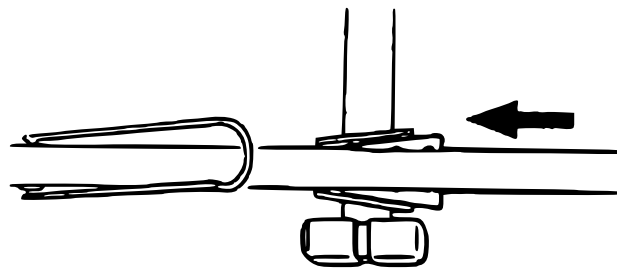

Figure 7: Topview

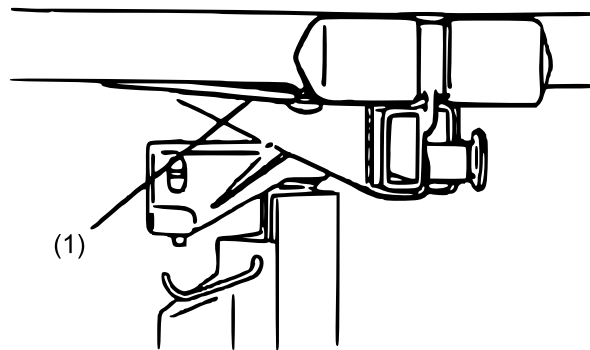
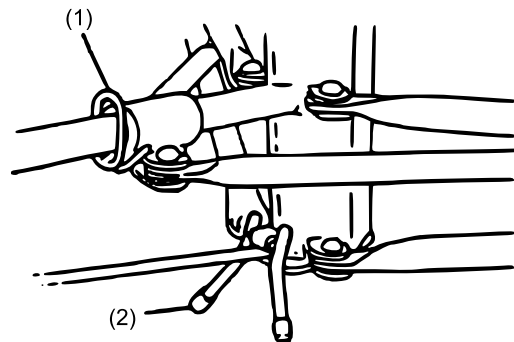

Figure 8

Use instructions

Slide yoke ring

Press down on the slide yoke ring **(1)** to unlatch the two forward legs so they can be rotated out to the working position of the lift or in to its storage position. A spring-loaded pin snaps into a hole on the bottom of the slide tube, to lock the folding legs position.



Backstop

Pivot the backstop **(2)** down to prevent the base from rolling backward during assembly. Tilt it up to allow the unit to wheel freely.

Outriggers

The outriggers on the crossarms extend for supporting a longer drywall panel. — To extend an outrigger, pull out the lock pin **(1)** with your right hand until you can slide the outrigger **(2)** out with your left hand. The lock pin can engage to lock the outrigger at one of three positions: fully retracted; extended to approx. 50 cm (21 in); extended to approx. 80 cm (33 in).

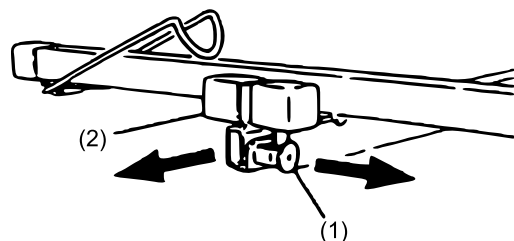

Important: Never load a drywall panel or operate the lift if the lock pins are not engaged at one of these three positions, or if the outriggers are extended beyond the 80-cm (33-in) position. To avoid damaging them, always fully retract the outriggers before transporting or storing the lift.



Panel support hooks

Open the support hook **(1)** on each crossarm to support the drywall panel when it is being loaded, or when the cradle is tilted. — To avoid damaging them, always close the support hooks before transporting or storing the lift.

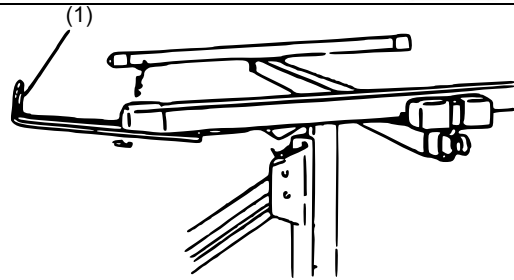

Slide bar lock

The slide bar lock **(1)** holds the winch assembly at its operating (fully extended) position. To fold the winch assembly against the frame (when disassembling the unit for transport or storage), disengage the lock by turning it counter-clockwise **(2)** as you lift on the slide bar.

When reassembling the unit for operation, extend the winch assembly all the way and then press it back slightly towards the frame to automatically engage the lock.

Never tighten the nut on the slide bar lock, or you will be unable to fold up the unit for transport and storage.

Tilt latch

To allow the cradle to tilt **(1)** (for loading a dry wall panel, or for raising the panel to a side wall or sloped ceiling), or to remove the cradle from the frame, pivot the tilt latch **(1)** out and down. To lock the cradle onto the frame without tilting, pivot the latch up to engage the stud **(2)** on the cradle.

Note: When it is in the level (non-tilted) position, the cradle will also tilt up to 10° side-to-side.

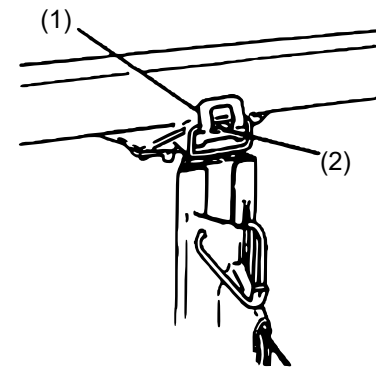
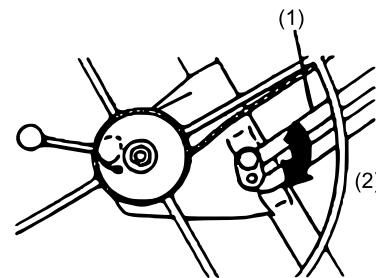

Brake arm

A spring-loaded brake holds the cradle at whatever height you raise it by cranking the winch wheel. To lower the cradle, control the backward rotation of the winch by grasping the wheel handle as you carefully raise the brake arm **(1)** to release the brake.

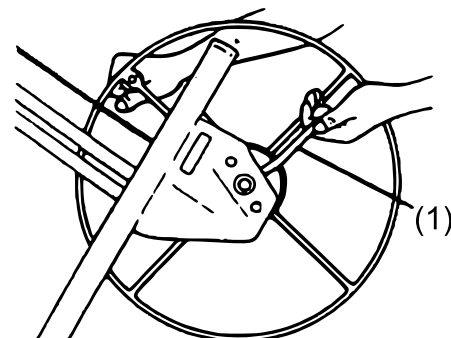

Winch wheel, handle, and post

Cranking the winch wheel **(1)** (using the wheel handle **(2)**) coils or uncoils the cable that raises or lowers the cradle.

Grasp the post **(3)** for leverage when cranking the winch.

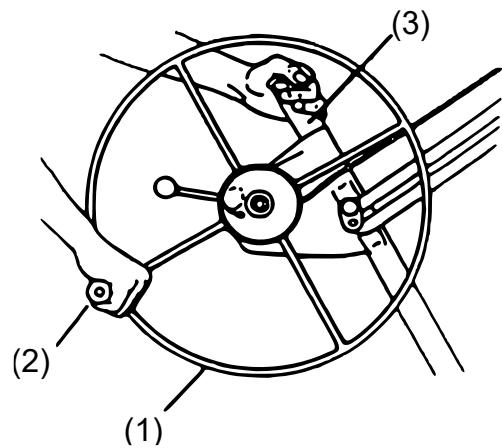

Retaining hook

The retaining hook **(1)** secures the telescoping sections inside the frame, for transport and storage.

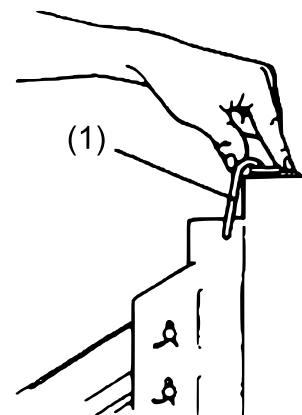

Operating instructions

Safety check before operation

Before you begin operating the lift each day:

- Carefully inspect the unit for wear or damage. Pay special attention to the cable.
- Be sure that the lift is at working room temperature before operating.
- Be sure that the winch brake drum is clean and dry before operating.

To load a drywall panel

1. Set (lower) the backstop, so the lift will not roll backward.
2. Swing open the panel support hooks on the two crossarms. Be sure that the cradle is turned so the support hooks are on the opposite side from the winch wheel.
3. Extend the crossarm outriggers on the cradle as needed to fully support the length of the drywall panel.
4. Release the tilt latch to tilt the cradle.
5. Hold the drywall panel with its face paper toward the tilted cradle, and load the panel onto the lift as shown (Fig. 10). Set the panel onto the support hooks, and carefully lean it against the crossarms.
6. If installing the panel on a flat ceiling, tilt the cradle back up to its level position and lock the tilt latch. If installing the panel on a side wall or a sloped ceiling, leave the cradle tilted.
7. Raise the backstop on the base, and carefully roll the lift close to the position where the panel will be installed.



ATTENTION!

To avoid serious injury, follow all "Important precautions" (see above).



ATTENTION!

Always wear a hard hat when operating!



ATTENTION!

To avoid injury: Only lift one panel at a time! Never lift more than 70 kg (150 lbs)!

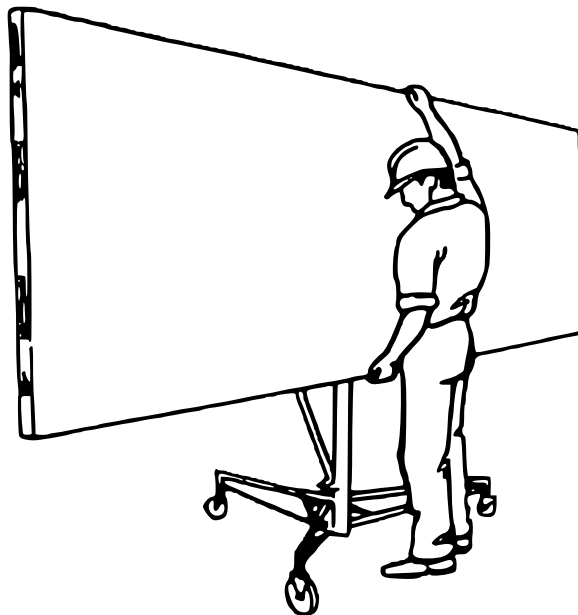

Figure 10

To raise the panel

IMPORTANT: Always lower the backstop before raising the panel to a sloped ceiling or a side wall.

Crank the winch wheel in the direction shown until the panel is at the desired height. Hold the post with the other hand.

The brake is spring-loaded to automatically hold the cradle at the selected height when you stop cranking.

To lower the panel

1. Grasp the wheel handle with your right hand so you can restrain the backward rotation of the winch.
2. Retain your hold on the winch handle. Carefully release the brake with your left hand and slowly rotate the wheel backward to lower the cradle to the desired height.

Disassembly and storage

Always store the lift in a dry, protected area.

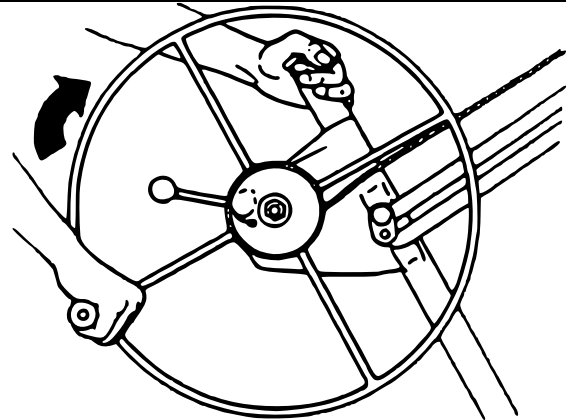
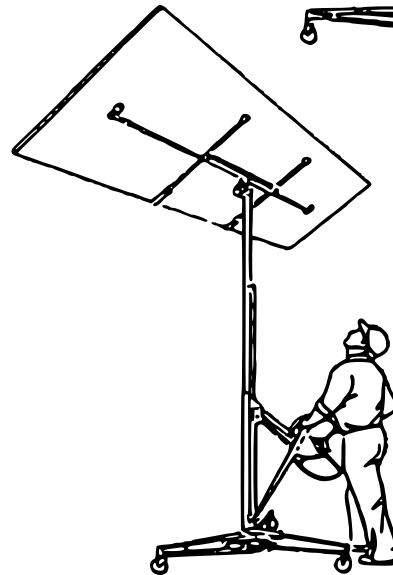
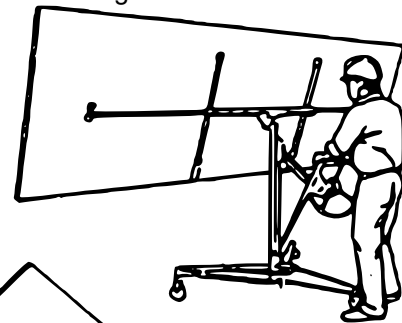

Figure 11



Figures 12 and 13

ATTENTION!

To avoid serious injury, watch for overhead obstructions when raising panel.

- (1) = Restrain the backward rotation of the winch.
- (2) = Release the brake carefully.
- (3) = To lower the panel

ATTENTION!

Cradle drops rapidly when brake arm is released. Control winch with your right hand on wheel handle before releasing the brake!

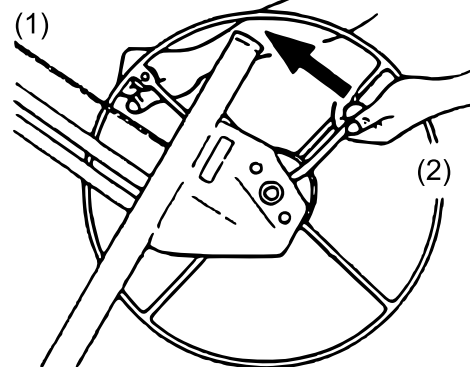

(3)
Figure 14

Disassembly

To disassemble the drywall, lift for transport or compact storage:

1. Crank the cradle all the way down.
2. Slide the cradle outriggers all the way in until they latch. Close the panel support hooks.
3. Remove the crossarms by pressing the spring tab on the bottom and sliding the crossarm out of the tapered socket (Fig. 15).
4. Unlock the cradle tilt latch. Lift the cradle (about 8 cm or 3 in) until you can remove it from the frame.
5. Rotate the winch wheel one full rotation forward as shown. This will raise the inner telescoping section.
6. Unlock the winch assembly by lifting the slide bar with your left hand while you rotate the slide bar lock counter-clockwise with your right hand.
7. Hold the slide bar lock in this disengaged position and press down on the telescoping sections in the frame with your left hand. The winch assembly will move toward the frame housing.
8. Crank the telescoping sections all the way down. Swing up the retaining hook as shown, and crank the telescoping sections back up slightly until secured by the hook.
9. Hold the retaining hook in this position with your left hand, and rotate the winch forward with your right hand.
10. The winch assembly will fold up against the frame. When the slide bar contacts the frame, tighten the cable by turning the wheel further (just enough to hold the winch assembly in this position).
11. Carefully lift the frame/winch about 3 cm (1 in) to free it from the tripod base.
12. To fold the base, press down on the slide yoke ring and pivot the forward legs in until they lock in the closed position.

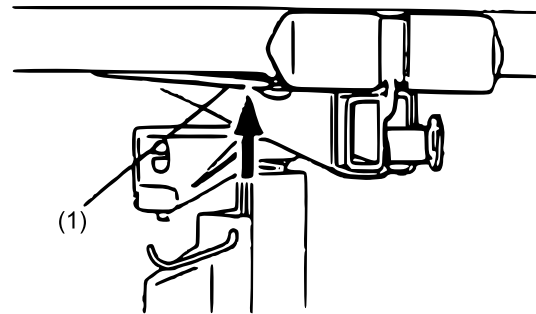

Figure 15

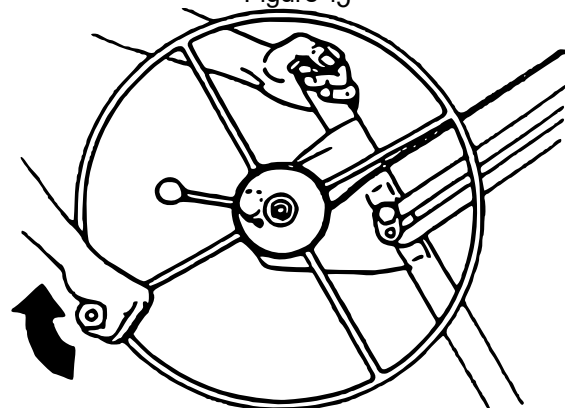

Figure 16

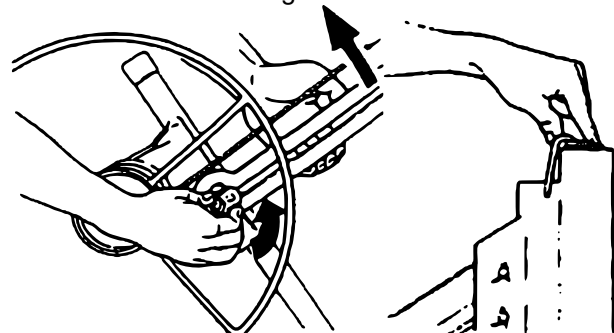

Figure 17

Figure 18

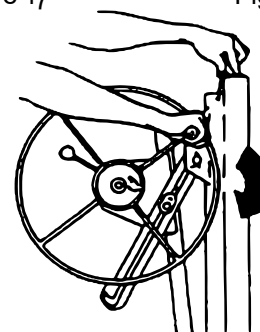

Figure 19



Maintenance

- Inspect the cable before each work day. Replace it at the first sign of wear (refer to the instructions supplied with the replacement cable)!
- Occasionally oil the cable pulleys. Crank up the telescoping sections for access to the internal cable pulley. Never allow oil or grease to contact the surface of the winch brake drum.
- Occasionally oil the caster bearings.
- If the telescoping sections of the frame do not operate smoothly, apply household paraffin to the sliding surfaces.



CAUTION

When the brake arm is released, the lift can retract very quickly. Before releasing the brake, always hold the winch with the right hand.

Parts diagram and parts list

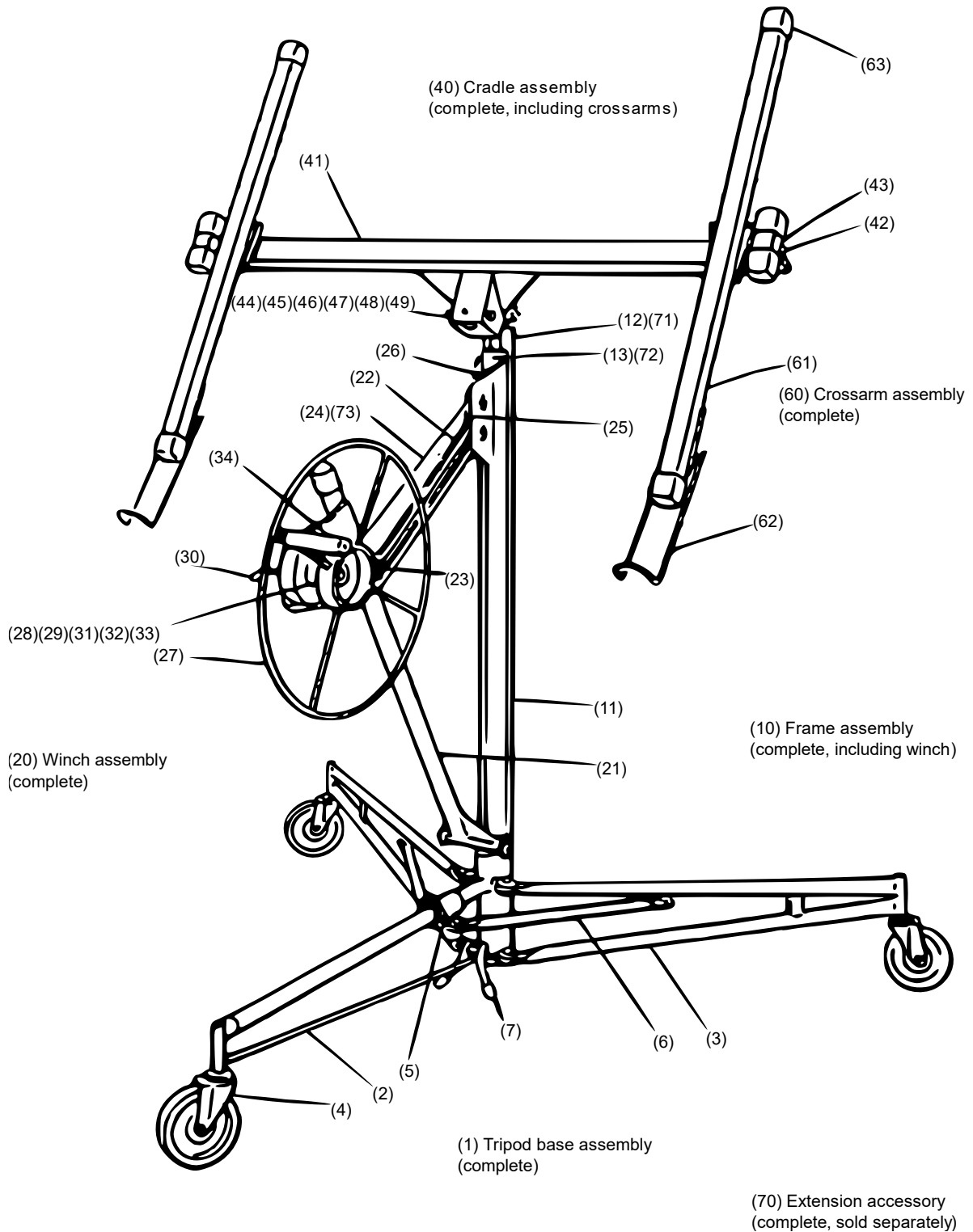



No	Name	Qty.	No	Name	Qty.
<i>Tripod base</i>			<i>Cradle assembly</i>		
1	Tripod base assembly	1	40	Cradle assembly	1
2	Centre leg (with fasteners)	1	41	Cradle body	1
3	Outer leg (with fasteners)	2	42	Outrigger lock pin (with spring and clip)	2
4	10-cm (4-in) caster	3	43	Outrigger (with end caps)	2
5	Slide yoke ring tension spring	1	44	Cradle mounting lead assembly	1
6	Tie arm (with fasteners)	2	45	Mounting head body	1
7	Rubber backstop tip	2	46	Cradle tilt latch (with fasteners)	1
<i>Frame</i>			47	Tension spring	1
10	Frame assembly (including winch assembly)	1	48	Compression spring	2
11	Frame housing	1	49	Hinge pin (with bolts)	1
12	10-cm (4-ft) inner telescoping section	1			
13	10-cm (4-ft) outer telescoping section (with pulley)	1			
<i>Winch assembly</i>			<i>Cradle crossarms</i>		
20	Winch assembly	1	60	Crossarm assembly	2
21	Winch host (with pin and fastener)	1	61	Crossarm body	2
22	Slide bar (with axle and cotter pin)	1	62	Panel support lock (with fasteners)	2
23	Slide bar lock (with fasteners)	1	63	Crossarm end caps	2
24	411-cm (13½ -ft) cable	1			
25	Cable pulley (with axle and cotter pin)	3	<i>Extension accessory (sold separately)</i>		
26	Retaining hook	1	70	Extension accessory	1
27	Winch wheel (with flange bearings)	1	71	183-cm (6-ft) inner telescoping section	1
28	2.22-cm (7/8-in) bushing	1	72	183-cm (6-ft) outer telescoping section	1
29	M12×125 bolt (with fasteners)	1	73	528-cm (17½ -ft) Cable	1
30	Brake arm assembly	1			
31	Brake lining (with fasteners)	1			
32	Brake arm tension spring	1			
33	Brake hub (with bolts)	1			
34	Winch wheel handle	1			

Important Note:

Reproduction and any commercial use (of parts) of this operating manual, requires a written permission of WilTec Wildanger Technik GmbH.