

Operating instructions

Air Cooler 64849

wiltec



Illustration similar, may vary depending on model

Please read and follow the operating instructions and safety information prior to initial operation.

Technical changes reserved!

Illustrations, functional steps, and technical data may deviate insignificantly due to continuous further developments.



The information contained in this document may alter at any time without prior notice. No part of this document may be copied or otherwise duplicated without prior written consent. All rights reserved. WilTec Wildanger Technik GmbH cannot be held liable for any possible mistakes in this operating manual, nor in the diagrams and illustrations shown.

Although WilTec Wildanger Technik GmbH has made every possible effort to ensure that this operating manual is complete, accurate, and up-to-date, errors cannot be ruled out entirely.

If you have found an error or wish to suggest an improvement, we look forward to hearing from you. Send us an e-mail to:

service@wiltec.info

or use our contact form:

<https://www.wiltec.de/contacts/>

The most recent version of this manual in several languages can be found in our online shop:

<https://www.wiltec.de/docsearch>

Our postal address is:

WilTec Wildanger Technik GmbH
Königsbenden 12
52249 Eschweiler – Germany

To return your goods for exchange, repair, or other purposes, please use the following address. Attention! To allow for a trouble-free complaint or return, it is important to contact our customer service team before returning your goods.

Retourenabteilung
WilTec Wildanger Technik GmbH
Königsbenden 28
52249 Eschweiler – Germany

E-mail: **service@wiltec.info**

Tel: +49 2403 55592-0

Fax: +49 2403 55592-15



Introduction

Thank you for choosing to purchase this quality product. To minimise the risk of injury, we ask you to always take some basic safety precautions when using this product. Please read this operating manual carefully and make sure that you understand it. Keep these operation instructions in a safe place.

Intended use/properties of the product

- Rapid cooling by evaporative cooling
- Long-lasting cooling effect thanks to the use of cooling packs
- Large water circuit for fast and long-lasting cooling
- Customisable air channel of tube pump, thereby increasing the air volume
- Timer function from 1 hour to 9 hours
- Simple operation by remote control
- Removable double mesh filter to simplify cleaning
- Protection against water shortage

Safety instructions

General remarks

- This fan is designed for a 220-V/50-Hz power connection.
- Disconnect the mains plug from the power supply before carrying out cleaning and maintenance work or transporting the fan. Do not pull the plug out of the socket by the cable and do not operate the device with damp or wet hands. **Danger of electric shock!**
- Ensure that the power cable is not damaged, excessively bent, stretched, knotted, or strained. Never operate the device if you notice any damage to the power cable or mains plug. For safety reasons, damaged power cables and plugs may only be replaced by a qualified electrician in order to avoid hazards.
- Do not insert any foreign objects or limbs into the input or output. This can lead to injuries and/or reduce the air flow.
- Do not operate this device in areas exposed to explosion hazards.
- Avoid dripping water and proximity to fire. Ensure that no flammable or explosive objects are sucked in.
- Do not spray any pesticides or cleaning agents on the fan to prevent damage to the rubber coating.
- Clean the fan with a cleaning fluid. Let the device dry off after cleaning it with a damp material. Do not operate it as long as it is wet.
- Do not expose the device to direct water jets.
- If the fan will not be used for a longer period, set all switches to "Off" and pull the plug out of the socket.
- Do not try to repair the device yourself. All repair work must be done by an expert.
- Do not sit nor stand on the device.
- This product is not a toy. Keep children and pets at a safe distance. Only use the device under supervision.
- Check the device and all connecting parts for functionality and completeness before each use. Should the device or one of the hoses connected be damaged, it must not be used any longer.
- When setting up the device, ensure that it is positioned at a safe distance from walls and objects.
- Ensure that the air inlet and outlet are always free of dirt and other blockages.
- Never drink the water from the water tank. There is a health risk.
- The water in the water tank should be changed regularly (approx. every 3 days). Otherwise, microorganisms can form that pose a health risk.
- Only fill the water container with fresh drinking water, ice cubes made from drinking water, and/or suitable ice packs.
- Keep the ice packs away from children and animals.
- Cold packs must never be opened. The liquid in the ice packs can be harmful to your health.

- Ice that may form on the ice packs must not be eaten. There is a health risk.

Precautions for use

- Only use the device to cool the air indoors. Observe all instructions in the user's manual.
- Place the fan on a level surface. It must not be operated in a slope or lying position.
- If you want to transport the device, disconnect the mains plug from the power supply beforehand. Then pick it up by the rear handle.
- Only transport the device in an upright position and with the water tank empty.
- Do not use the device in locations with high humidity, heavy dust accumulation, or temperatures above 40 °C.
- Make sure that the water level in the tank does not fall below the lowest mark, otherwise the cooling function cannot be used.
- Never insert limbs or foreign objects through the guards.
- Do not place any objects (e.g., items of clothing) on the device.
- Do not operate the device in explosive areas.
- Do not make any technical modifications to the compressor.
- Always operate the device properly. Improper operation increases the risk of accidents and injuries.
- Maintenance and repair work that requires the housing to be opened may only be carried out by a qualified electrician.
- Always keep the device out of children's or infirm persons' reach. Do not permit children to use the device without supervision. This device can be used by children from 8 years on as well as by persons with reduced physical, sensory, and mental abilities or lack of experience and/or knowledge if they are supervised or have been instructed concerning the proper and safe use of the device and are able to understand the risks connected to it. Children must not play with the device. Children may only clean and maintain the device if they are supervised.

Parts list

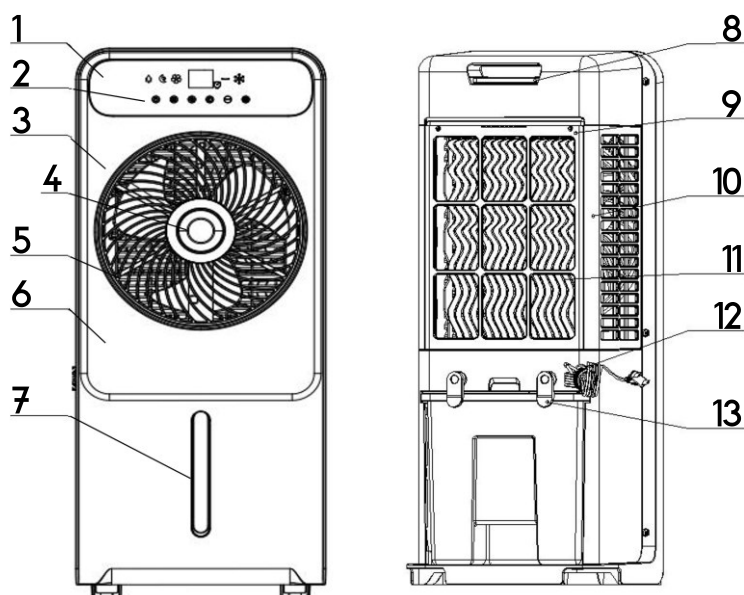

No	Name	No	Name	No	Name
1	Control panel	6	Front cover	11	Water filter
2	Touch button	7	Water tank	12	Power cord
3	Decorative panel	8	Rear cover	13	Water-tank lock
4	Decorative cover	9	Rear guard		
5	Front guard	10	Side guard		

Use

Before use, fill the tank with clean water as shown below.

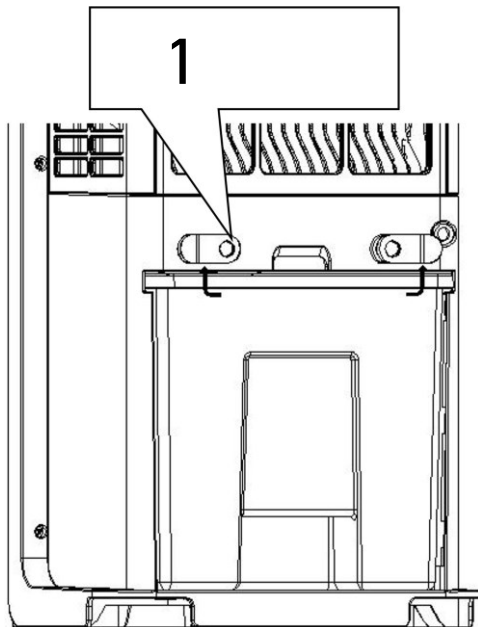

Turn the latch 90° to open.

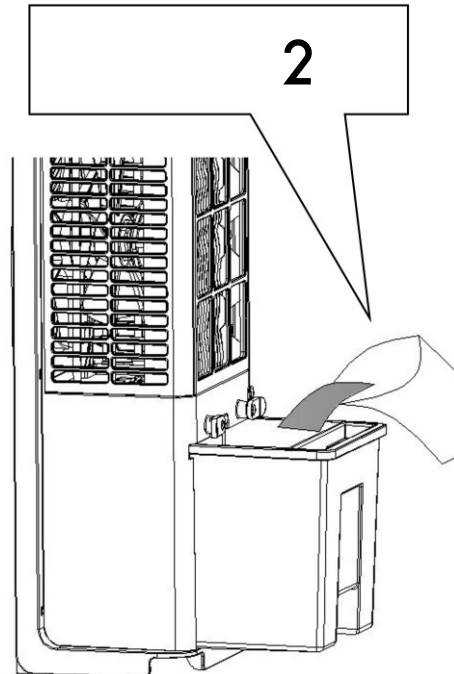

Fill up the water tank.

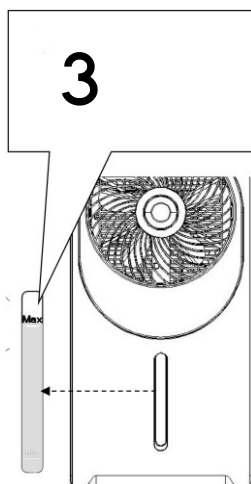

Do not exceed the maximum fill level of the water to avoid overflowing when the device is being operated or moved.

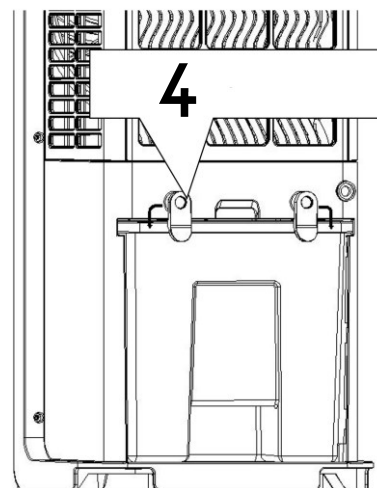

Turn the locking mechanism 90° to prevent the tank from slipping out.

Operational components

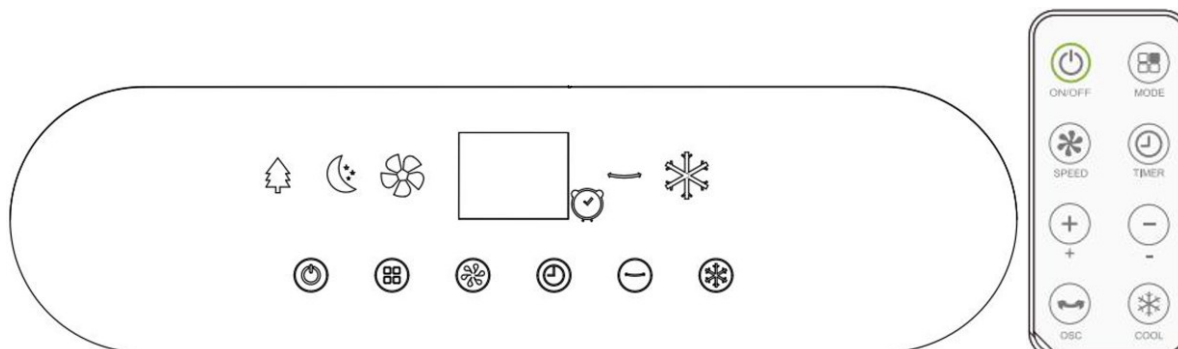

Fig.	Name	Description
	ON/OFF button	Press the ON/OFF button. The fan speed is set to level 5 as standard. The corresponding symbol lights up after switching on. Press the ON/OFF button again to switch off all functions. Settings are saved when the device is switched to stand-by mode.
	Mode	Press this button to change the type of the air flow. There are three setting options: normal – natural – sleep.
	Speed	Press this button to change the speed of the air flow. Levels from 1 (smallest level) to 12 (largest level) are available.
	Timer	Press this button to measure the time. The H symbol and the timer symbol with 1 h are displayed on the screen. The timer symbol changes in the sequence: <i>1 hour → 2 hours → 3 hours → 9 hours → time control off</i> . When the set time has elapsed, the fan stops rotating. The ventilation flaps are also closed, and the entire device is switched off.
	Cooling	Press this button to start the cooling function. If the device does not detect any water, a buzzer sounds three times, and the water pump stops. The cooling indicator flashes three times and then goes out.
	Oscillation	Press this button for the first time for a clockwise rotation. The corresponding indicator lights up. Press the button again so that the fan rotates anti-clockwise. Press the button again to switch off the rotation.

- Automatic switch-off: The device switches off automatically after 10 hours if no button is pressed.
- Switch-on: After inserting the plug into the socket, a beep sounds, and the operating indicator on the FND display panel lights up.

Using the remote control

- The buttons on the remote control work in the same way as the buttons on the control panel.
- The range of the remote control is approx. 5 m, the working angle 30–45°.
- If the remote control does not work even very close to the device, replace the battery.
- The remote control is not a toy. Never allow children to play with it.

Maintenance and storage

- Disconnect the mains plug from the power supply before cleaning.
- The housing can be cleaned with a cleaning fluid and a soft cloth. Do not use corrosive cleaning agents, petrol, alcohol, etc. to clean the plastic parts to avoid deformation or damage.
- Place the appliance in the box and store it in a dry place with sufficient air circulation.
- Clean the device as follows:

Water tank: Pull out the water tank, clean it with a brush, rinse it with clean water, dry it, and put it back into the device.

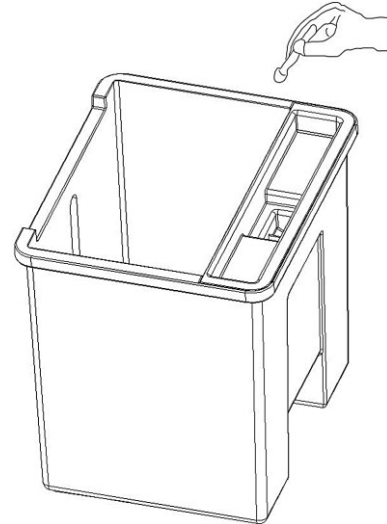

Rear cover: Remove the rear filter and clean it with a brush.



If you are not using the device after cleaning, you can place the mains cable on the corresponding holder (1).

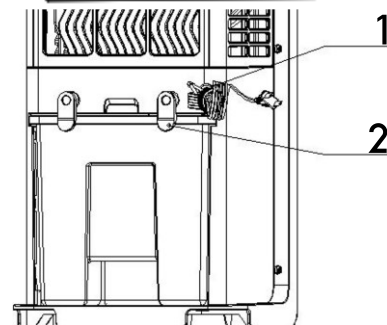

- Before storing, make sure that there is no water in the water tank. Place the device in the protective bag in the box. Store it in a dry and sufficiently ventilated place.



Technical specifications

Description	Symbol	Value	Unit
Maximum fan flow rate	F	15.62	m ³ /min
Fan power input	P	27.6	W
Service value	SV	0.57	(m ³ /min)/W
Off power consumption	P _{off}	0.48	W
Fan sound power level	L _{WA}	61	dB (A)
Maximum air velocity	c	2.62	m/s
Seasonal electricity consumption	Q	9.37	kWh/a
Measurement standard for service value	IEC 60879:2019 EN 60704-1:2010 +A11:2012 EN 60704-2-7:2020		

Regulations for waste disposal

The Waste Electrical and Electronic Equipment Directive (WEEE Directive, 2012/19/EU) of the EU was implemented in the German law related to electrical and electronic equipment and appliances.

All WilTec electric devices that fall under the WEEE directive are labelled with the symbol of a crossed-out wheeled rubbish bin. This symbol indicates that this electric device must not be disposed of with the domestic waste.

WilTec Technik GmbH is registered with the German registration authority EAR (Stiftung Elektro-Altgeräte Register) under the WEEE-registration number DE45283704.

Disposal of used electrical and electronic devices (intended for use in the countries of the European Union and other European countries with a separate waste collection system for these devices).

The symbol on the packaging or the product itself indicates that this product must not be treated as normal domestic waste but must be disposed of at a recycling collection station for electrical and electronic waste.

By disposing of this product correctly, you contribute to the protection of the environment and the health of your fellow people. Inappropriate disposal threatens the environment and health.



Material recycling helps to reduce the consumption of raw materials.

Additional information about the recycling of this product can be provided by your local commune, the municipal waste disposal facilities, or the store where you purchased the product.

Address:
WilTec Wildanger Technik GmbH
Königsbenden 12 / 28
52249 Eschweiler Germany

Important note:

Reproduction and any commercial use (of parts) of this operating manual, requires a written permission of WilTec Wildanger Technik GmbH.