

Operation Manual

Petrol Engine

99200–99202, 99204–99207, 99209, 99210

XPO ^{the} **tool**
experts



Illustration similar, may vary depending on model

Read and follow the operating instructions and safety information before using for the first time.

Technical changes reserved!

Due to further developments, illustrations, functioning steps, and technical data can differ insignificantly.

Updating the documentation

If you have suggestions for improvement or have found any irregularities, please contact us.



The information contained in this document may alter at any time without previous notice. It is prohibited to copy or spread any parts of this document in any way without prior written allowance. All rights reserved.

The WilTec Wildanger Technik GmbH cannot be held accountable for any possible mistakes in this operating manual, nor in the diagrams and figures shown.

Even though, the WilTec Wildanger Technik GmbH has undergone biggest possible efforts to ensure that the operating manual is complete, faultless, and up to date, mistakes cannot be entirely avoided.

If you should find a mistake or wish to make a suggestion for improvement, we look forward to hearing from you.

Send an e-mail to:

service@wiltec.info

or use our contact form:

<https://www.wiltec.de/contacts/>

The most recent version of this manual in various languages can be found in our online shop via:

<https://www.wiltec.de/docsearch>

Our postal address is:

WilTec Wildanger Technik GmbH
Königsbenden 12
52249 Eschweiler
Germany

To return orders for exchange, repair, or other purposes, please use the following address. Attention! To allow for a smooth execution of your complaint or return, it is important to contact our customer service team before returning the goods.

Returns Department
WilTec Wildanger Technik GmbH
Königsbenden 28
52249 Eschweiler

E-mail: **service@wiltec.info**

Tel: +49 2403 55592-0

Fax: +49 2403 55592-15



Introduction

Thank you for purchasing this quality product. **To minimise the risk of injury we urge that our clients take some basic safety precautions when using this device. Please read the operation instructions carefully and make sure you have understood its content.**

Keep these operation instructions safe.

Product features

- One-cylinder, 4-stroke engine
- Hand or electric starter
- Powerful air-cooling system
- Overhead valve (OHV)
- TCI Ignition Module
- Fan hood made of particularly silent steel plate

Our series of air-cooled four-stroke gasoline engines has been developed in terms of material and energy saving. Due to their compact design, the devices are easy to carry to every location and convenient to handle. They offer a wide range of applications in the fields of craft, industry, horticulture and agriculture, or household.

This manual will help you use your engine optimally. Please read it carefully **before** using the device. By doing so, the life of the device will be significantly increased.

Please contact us if you have any questions or comments about these instructions. In some cases, the device equipment may vary from the kind described in this guide.

Safety precautions

Please follow the following tips and ideas for your own safety, otherwise damage to the equipment or operator's injury may occur.

- Make sure that the engine is only operated in well-ventilated environments, otherwise a health risk may occur because of the fumes.
- In other persons' vicinity, the engine must work with due diligence. Make sure that the exhaust pipe is free and accessible; it must not be covered or blocked.
- Before filling the tank with fuel, the engine must always be switched off.
- The tank must not be overfilled.
- If the fuel is spilled on the device when filling, it must be removed before starting the engine.
- Before changing the oil make sure that the cap of the tank is closed, so no oil can go into the petrol tank.
- Do not use the unit near open flames, flammable or explosive substances or gases, and flying sparks.
- The engine should be at least one 1 m away from house walls or other fixed facilities.
- Make sure that all moving and rotating parts are covered.
- While the device works, the individual components (e.g., the exhaust) become hot. Be careful when touching, because otherwise it may cause burns.
- Operate in a safe environment and keep children away from it while operating.
- Operate on a straight and solid surface. On slopes the device may leak fuel.
- A larger inclination can have, even with full oil level, negative influence on the gear.
- Take care when transporting the device; make sure there are no fuel leaks. We recommend that the tank is emptied and the fuel inlet valve closed.



Before commissioning the device keep the following advice in mind:

- Make sure that all fuel lines are connected and firmly attached, so that no leakage may occur.
- Make sure that all screws and nuts are firmly tightened.
- Check the fuel and oil level and if necessary, re-fill fuel or oil.

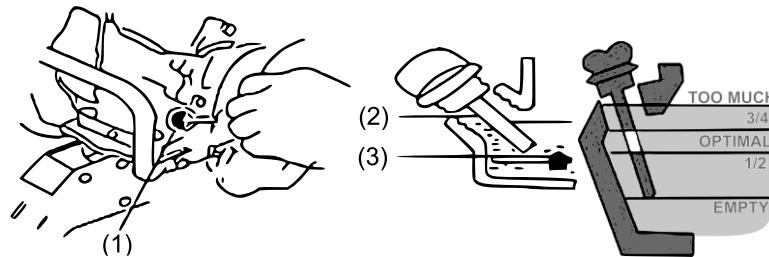

No	Name	No	Name
1	Oil level gauge	3	Min. oil level
2	Max. oil level		

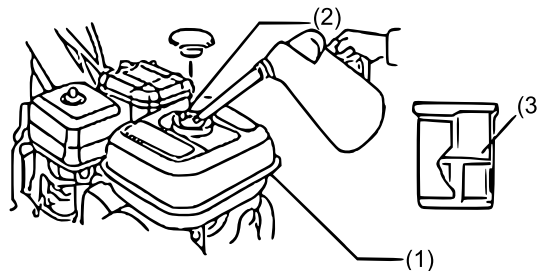

No	Name	No	Name
1	Fuel tank	3	Red mark for max. fuel level
2	Fuel cap		

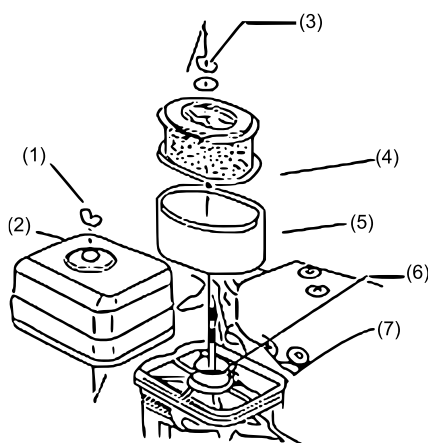

No	Name
1	Wing nut
2	Air filter housing
3	Wing nut
4	Air filter
5	Foam filter
6	Seal
7	Air filter holder

The air filter should be regularly checked and, if necessary, cleaned or replaced.

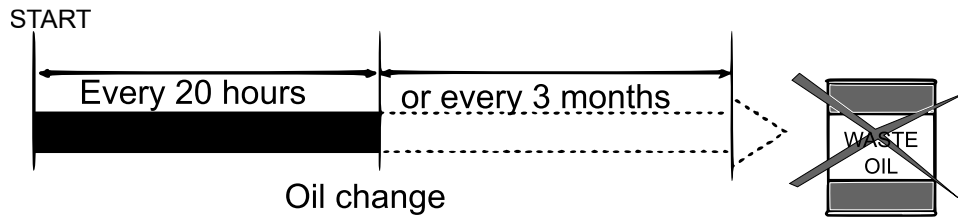

Crankshaft inclination		
Tolerable inclination	$\leq 20^\circ$	
Engine inclination		
Tolerable inclination	$\leq 20^\circ$	

Starting and stopping the engine

Open the throttle (1) and the drain screw (3) of the carburettor. Once the fuel runs out, the drain screw (3) may be refastened. Then you can start the engine as usual.

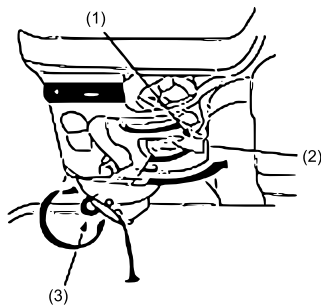

No	Name
1	Throttle lever
2	Throttle valve opened
3	Drain screw

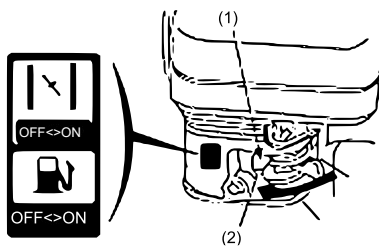

The engine may be run only within the rated power and rated speed. If you detect abnormal episodes, please stop the engine immediately and initiate corrective measures. The engine should not be charged during the first 1–3 min after the start.

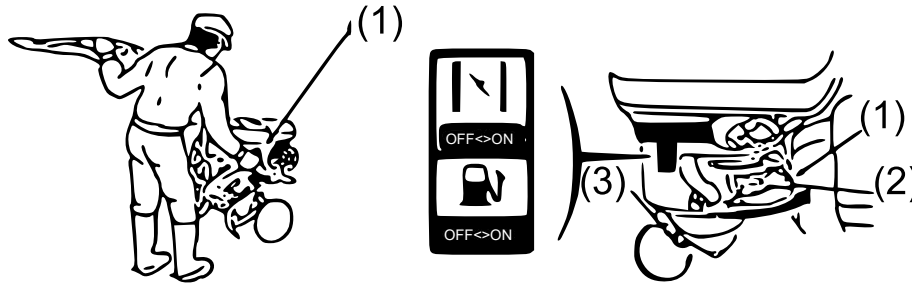

No	Name	No	Name
1	Choke	3	Carburettor drain screw
2	Choke not activated		

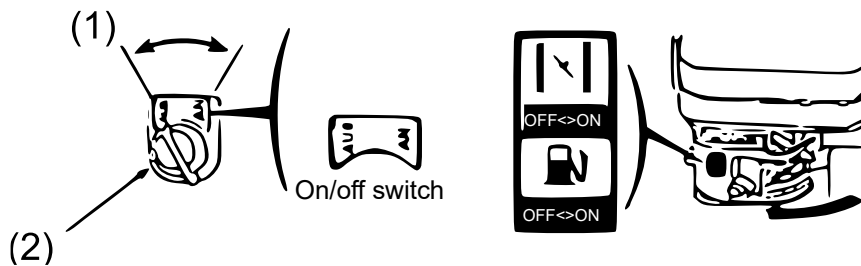

No	Name	No	Name
1	Ignition off	2	Ignition switch

If you want to stop the engine, reduce the speed to a minimum, set the choke to Off and turn the on/off switch to off. The engine should be shut immediately. The switch is located right on the crankshaft housing.

Regular maintenance

- Regularly clean the air filter; replace it in case it cannot be cleaned any more. It should be cleaned after approximately 25 hours of working.
- Check all fittings for tightness and re-tighten them if necessary.
- Regularly check the engine oil level.

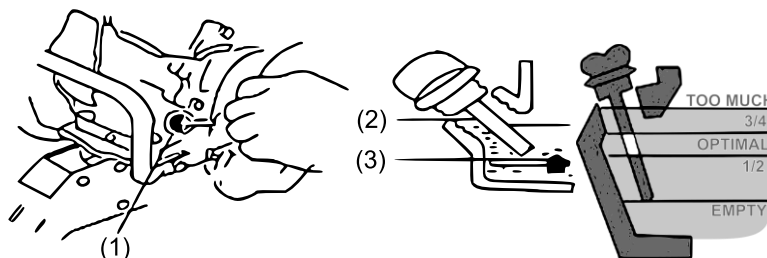

No	Name	No	Name
1	Oil level gauge	3	Min. oil level
2	Max. oil level		

Every 50 hours of operation, the spark plug should be cleaned, tested, or replaced if necessary. If the earth electrode is burnt too much or the spark plug worn, it should be exchanged against a new spark plug of the same type. **Only mount or dismount spark plugs in a cold engine. ONLY use ORIGINAL spark plugs!**

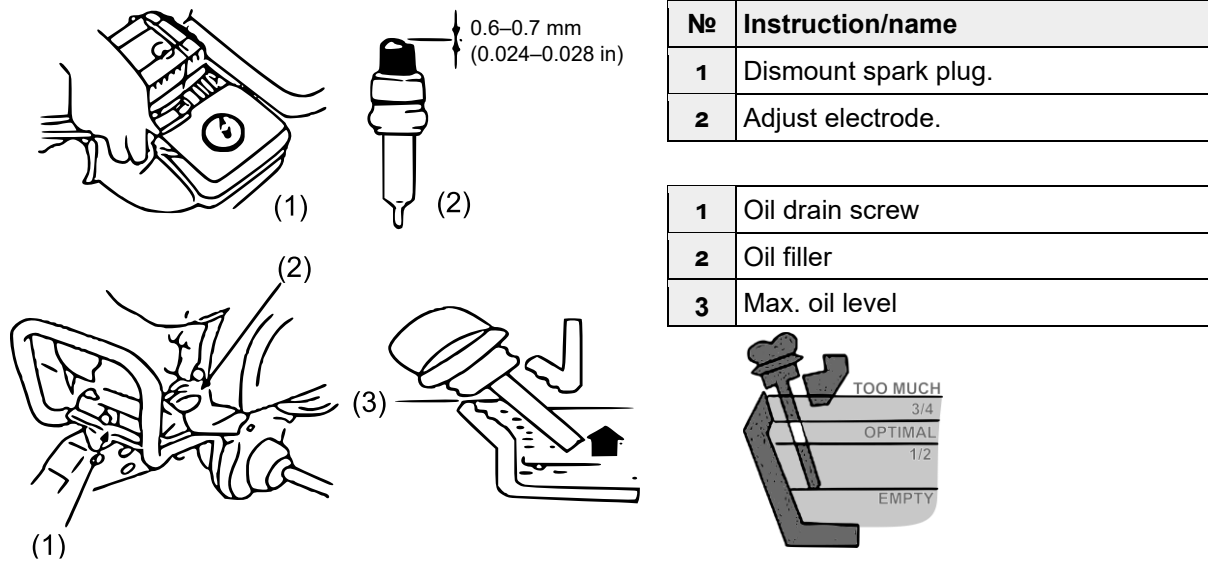

No	Instruction/name
1	Dismount spark plug.
2	Adjust electrode.

1	Oil drain screw
2	Oil filler
3	Max. oil level

Clean the fuel tank every 100 hours of operation. For this, the tank should be taken from the holder and rinsed. The fuel filter should periodically be cleaned.

If the engine shall be stored for long periods of time, the fuel tank shall be completely emptied and the carburettor emptied on his discharge screw. The engine oil should be discharged when the engine is hot, but switched off. Then re-fill new oil. The engine should be completely cleaned of dirt from the outside. The air filter and spark plug should be checked again and replaced or cleaned if necessary. The combustion chamber should be filled with some motor oil when the spark plug is unscrewed so that the combustion chamber is not oxidised. After that, the engine may be stored in a dry storage place.

Torques

Part	Nm (value)	
	200	270-420
Cylinder head screw	29±3	48±3
Crankshaft case screws	25±3	25±3
Connecting rod bolt	14±1	16±1
Fly wheel screws	80-90	120-140
Spark plug	20	
Spark plug gap (mm)	0,7-0,8 (0,028-0,031 in)	
Valve clearance (cold) (mm)	IN: 0,10 ± 0,15 EX: 0,15 ± 0,20	

Technical specifications

Item no.	99202	99204	99207/99210	99200/99205/99209
Engine designation	2000 (E)	270 (E)	390 (E)	420 (E)
Engine capacity (cm ³)	196	270	389	420
Spark plug type	F7TC			
Max. Power	4.1 kW with 3600 rpm	5.8 kW with 3600 rpm	7.8 kW with 3600 rpm	8.8 kW with 3600 rpm
Starting device	Recoil/Electric Start			
Engine oil type	SAE 10 W-30 mineral for winter/summer			
Fuel consumption (g/hp/h)	<380	<374		
Fuel type	Premium unleaded			
Tank capacity (premium unleaded) (ℓ)	3.6	6.0	6.5	
Engine oil capacity (ℓ)	0.55	0.95	1.1	
Cooling	Air cooled engine			
Weight (kg)	17/19	28/31	32.5/35.5	33/36
Dimensions (mm)	39×32×34.5	42×39.5×43	46.5×41.5×44	
Engine bore (mm)	68×54	77×58	88×64	90×66
Ignition	Transistor/magneto			
Engine stop system	Circuit to ground			

Item no.	/	99201	/	/
Engine designation	2000 (E)1/2	270(E)1/2	390(E)1/2	420(E)1/2
Engine capacity (cm ³)	196	270	389	420
Spark plug type	F7TC			
Max. Power	4.1 kW with 3600 rpm	5.8 kW with 3600 rpm	7.8 kW with 3600 rpm	8.8 kW with 3600 rpm
Starting device	Recoil/Electric Start			
Engine oil type	SAE 10 W-30 mineral for winter/summer			
Fuel consumption (g/hp/h)	<380	<374		
Fuel type	Premium unleaded			
Tank capacity (premium unleaded) (ℓ)	3.6	6.0	6.5	
Engine oil capacity (ℓ)	0.55	0.95	1.1	
Cooling	Air cooled engine			
Weight (kg)	18.5/20.5	29/32	33.5/36.5	
Dimensions (cm)	39×36×34.5	42×45.5×43	46.5×45.5×44	



Engine bore (mm)	68x54	77x58	88x64	90x66
Ignition	Transistor/magneto			
Engine stop system	Circuit to ground			

Wiring diagrams

Wire colours and codes

BL	Black	Br	Brown
Y	Yellow	R	Red
W	White	G	Green

Combination switch

	IG	E	BAT	ST
OFF	○	○		
ON				
START			○	○

With oil alert and without electric starter

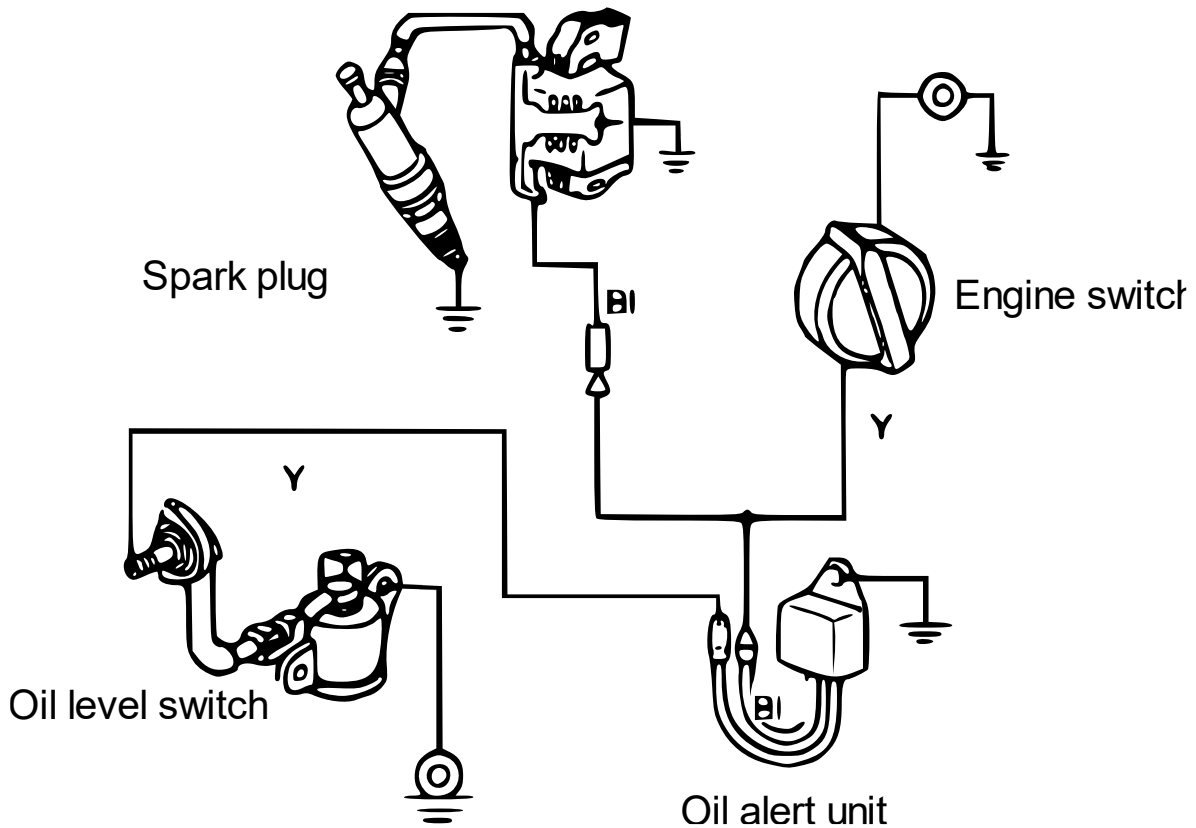

With oil alert and electric starter

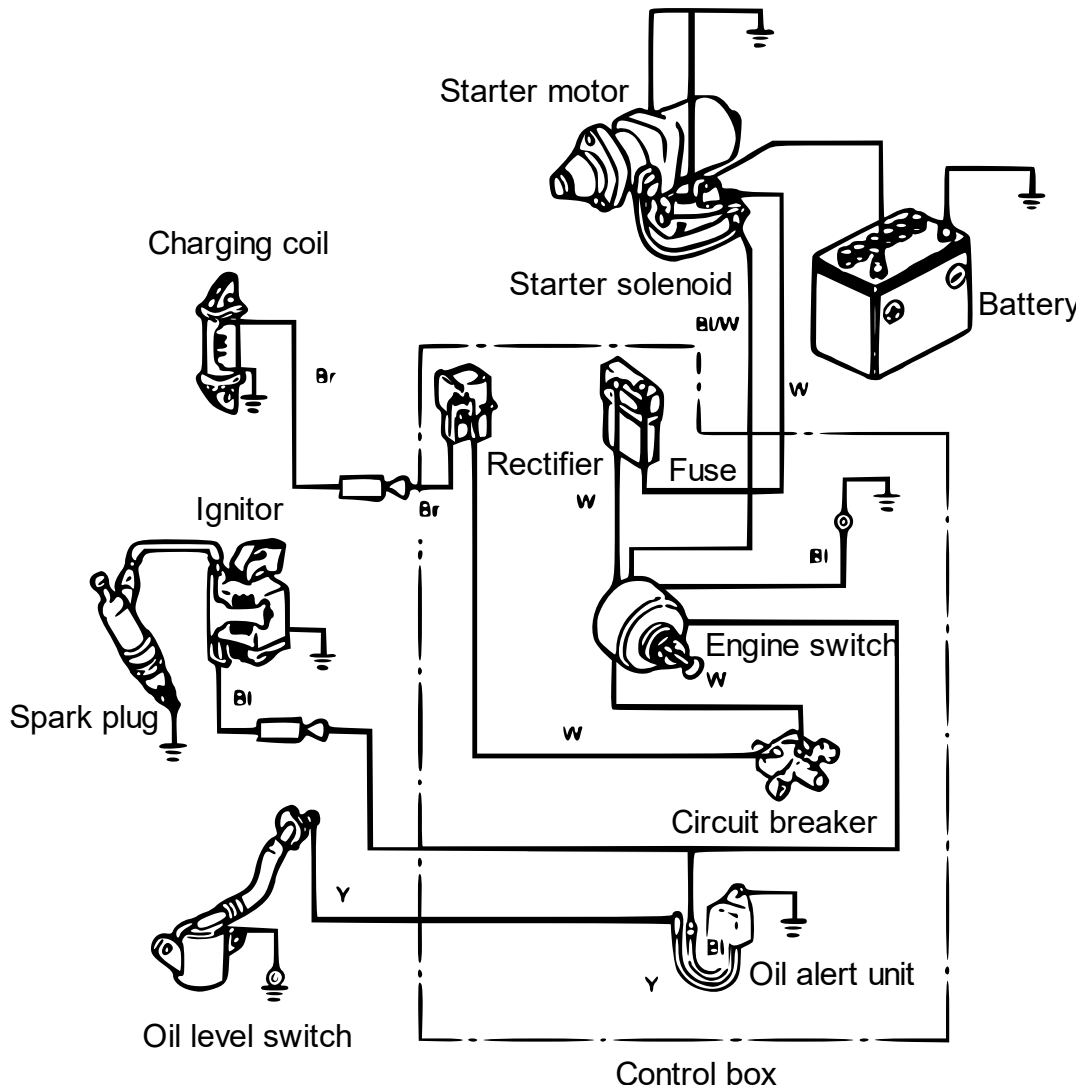

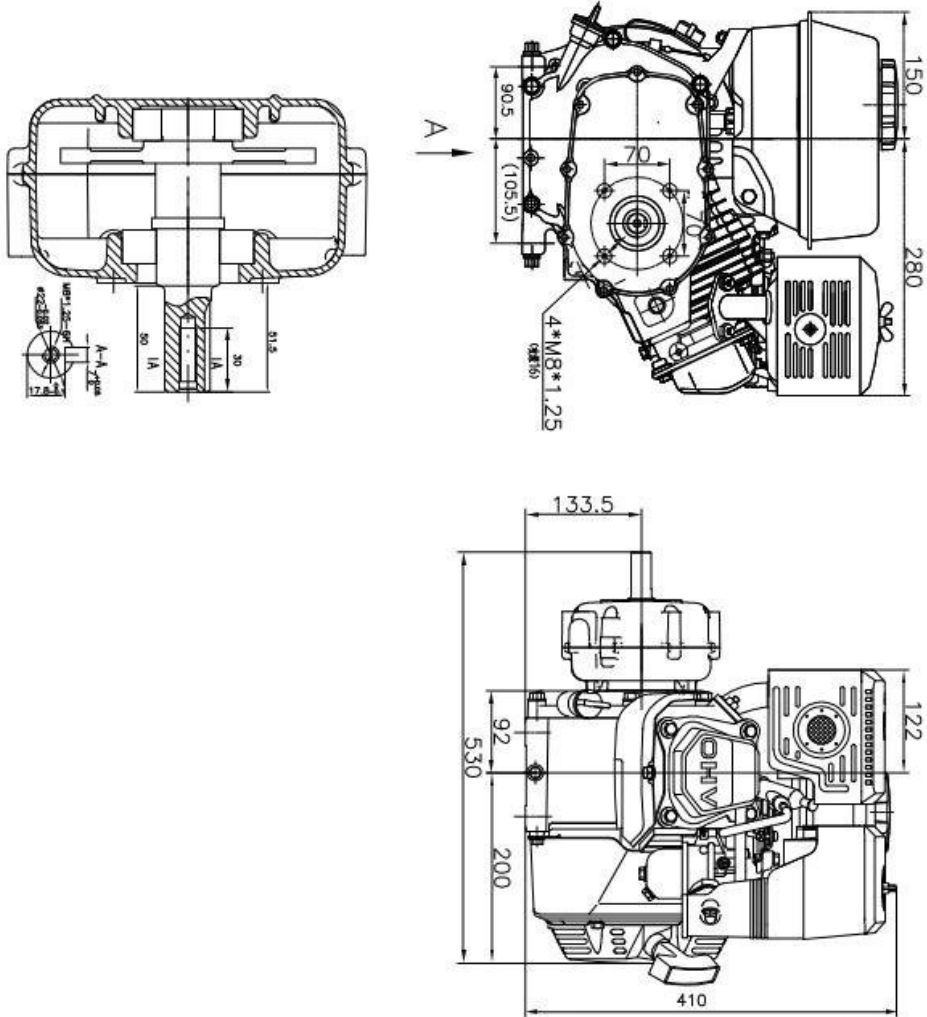

GK270

GK270

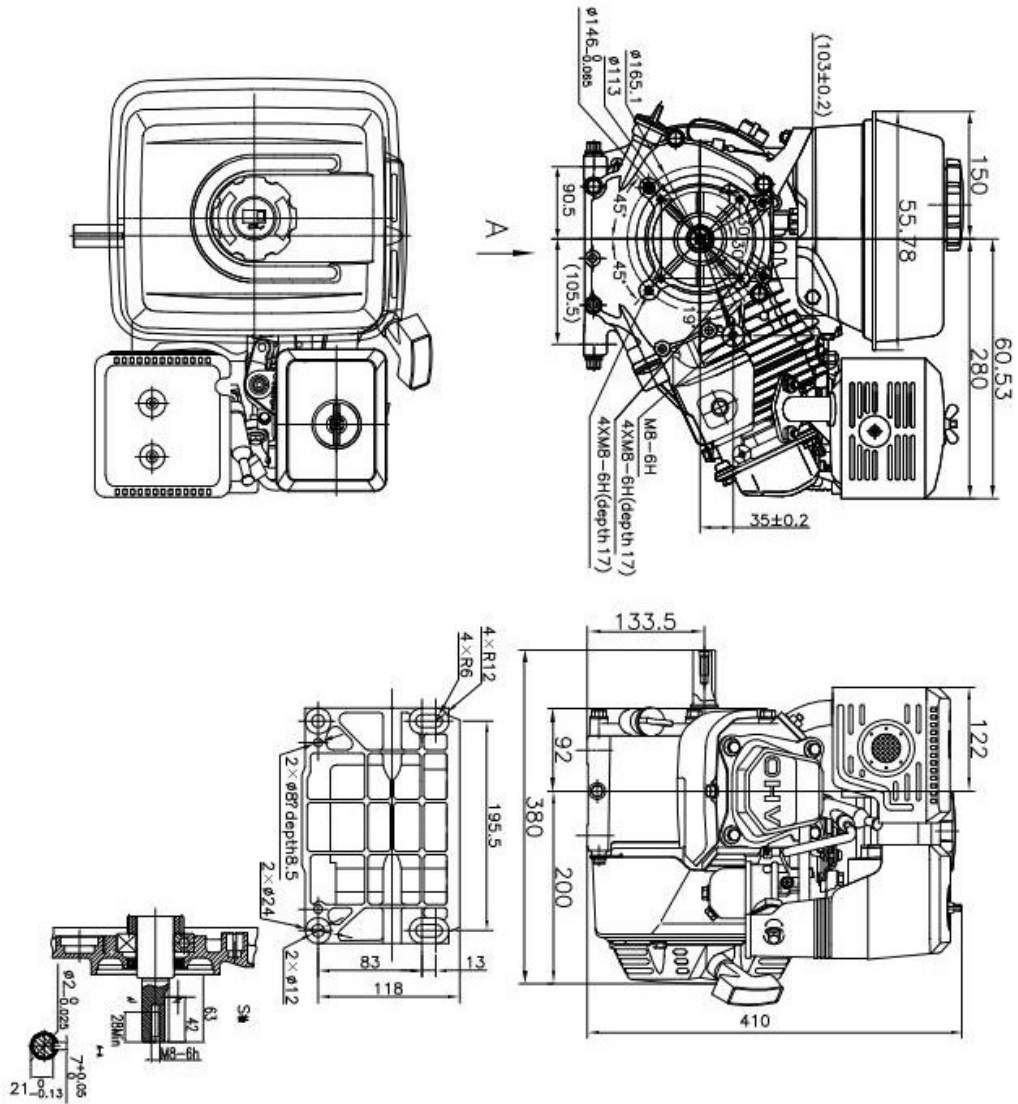

GK390 / GK420

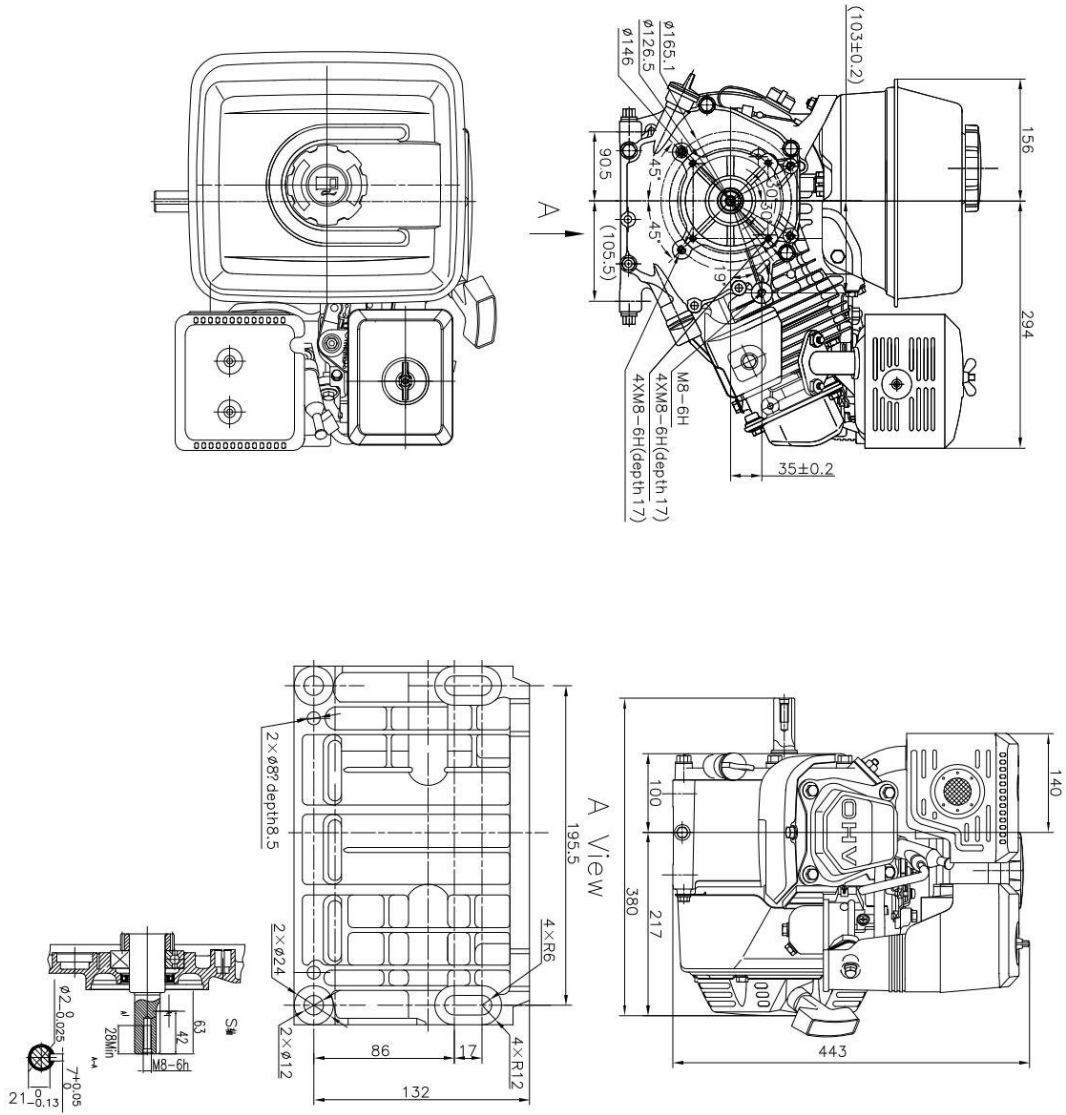

GK390/GK420

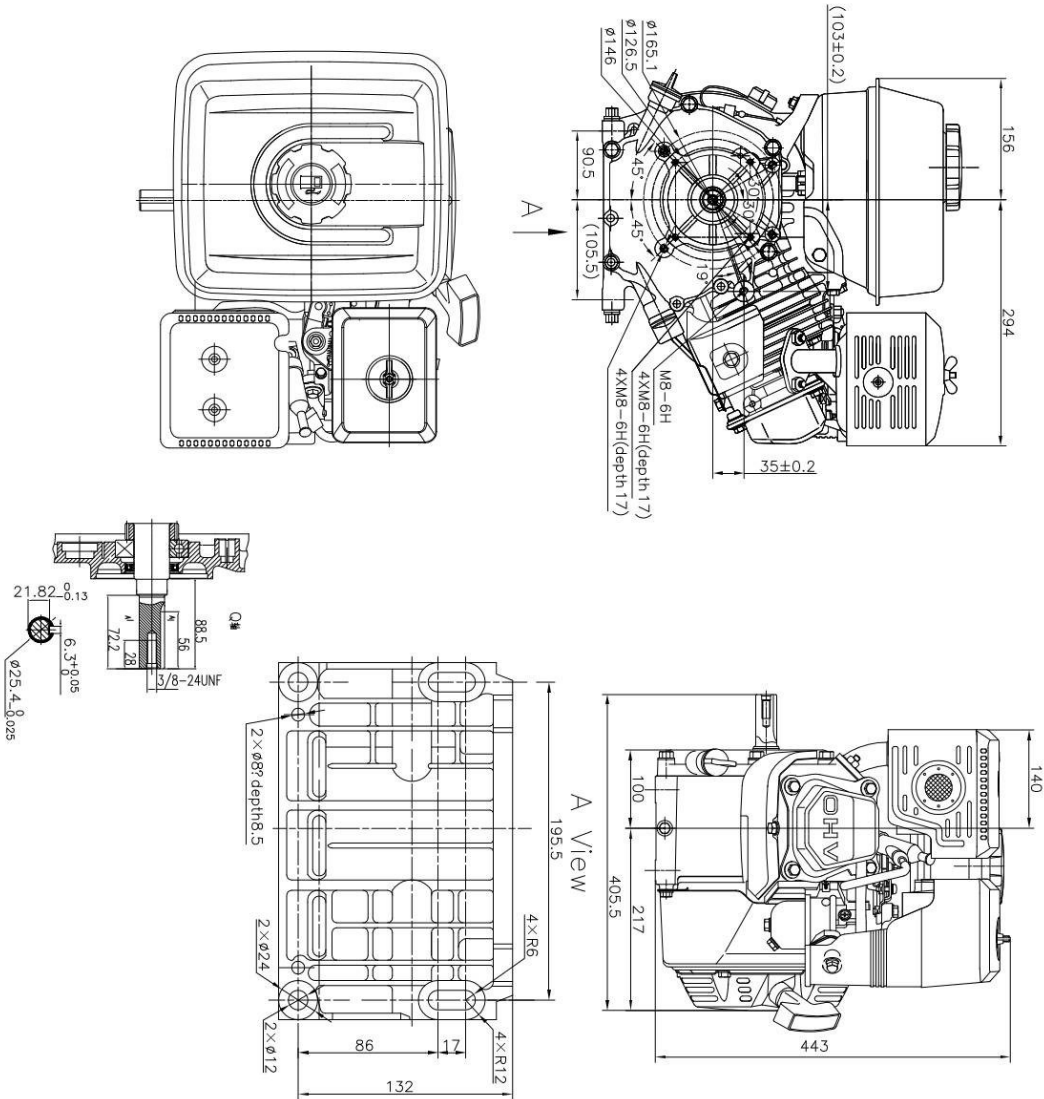

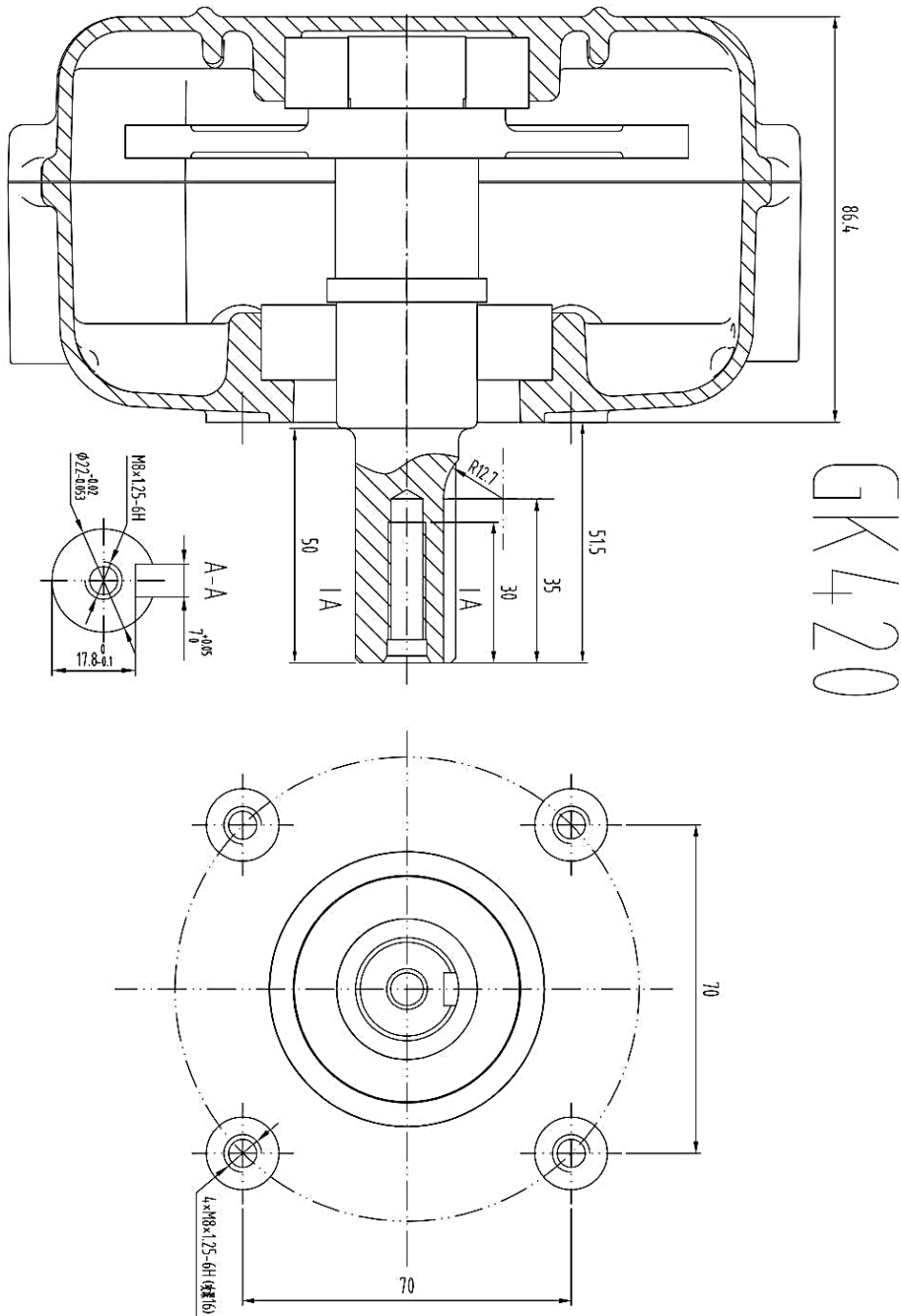

Important Note:

The reprint or reproduction, even of excerpts, and any commercial use, even in part, of this instruction manual require the written permission of WilTec Wildanger Technik GmbH.